

# SBAR

CE

**Automatic barrier**



**EN - Instructions and warnings for installation and use**

**IT - Istruzioni ed avvertenze per l'installazione e manuale per l'uso**

**FR - Instructions et avertissements pour l'installation et l'utilisation**

**ES - Instrucciones y advertencias para la instalación y el uso**

**DE - Installierungs-und Gebrauchsanleitungen und Hinweise**

**PL - Instrukcje i ostrzeżenia do instalacji i użytkowania**

**NL - Aanwijzingen en aanbevelingen voor installatie en gebruik**

**[www.latmet.com](http://www.latmet.com)**

SIA Lat Met: Reģ. Nr. LV 44103033222

"Meistari", Kocēnu novads,

Kocēnu pagasts, Latvija, LV4220

Tālrunis: +371 642 29800; E-pasts: [info@latmet.com](mailto:info@latmet.com)

**Nice**

# Contents

<b>Chapter 1 - WARNINGS AND GENERAL PRECAUTIONS</b>	
1.1 - Safety instructions	1
1.2 - Installation warnings	1
1.3 - Special warnings related to European Directives applicable to the product	1
1.3.1 - Installation criteria and special warnings related to essential requirements	2
<b>Chapter 2 - PRODUCT DESCRIPTION AND INTENDED USE</b>	3
<b>Chapter 3 - INSTALLATION</b>	
3.1 - Preliminary checks for installation	3
3.2 - Product application limit	3
3.2.1 - Product durability	3
3.3 - Typical system	3
3.3.1 - Modifying the factory settings of the Closure manoeuvre	4
3.4 - Barrier fixture	4
3.4.1 - If the support surface already exists	4
3.4.2 - If the support surface does not exist	4
3.5 - Pole installation	4
3.5.1 - Pole support assembly	4
3.5.2 - Pole assembly	4
3.6 - Manually releasing and locking the gearmotor	4
3.7 - Mechanical stop adjustment	4
3.8 - Pole balancing	4
<b>Chapter 4 - ELECTRICAL CONNECTIONS</b>	
4.1 - Description of the electrical connections	5
4.2 - Initial start-up and connection check	5
4.3 - Pre-set functions	5
4.4 - Recognition of the connected devices	5
4.5 - Recognition of limit positions on opening and closing	5
4.6 - Pole movement check	6
4.7 - Connecting a radio receiver	6
4.8 - Connecting the pole lights (optional accessory)	6
4.9 - Connecting the LED flashing light mod. XBA7 or traffic light to LED mod. XBA8 (optional accessories)	6
4.10 - Connection of other devices	6
4.10.1 - Programming unit Oview	6
4.10.2 - Buffer battery mod. PS124 (accessory)	6
4.10.3 - Solemyo System (photovoltaic supply)	6
<b>Chapter 5 - TESTING AND COMMISSIONING</b>	
5.1 - Testing	6
5.2 - Commissioning	7
<b>Chapter 6 - CONTROL UNIT PROGRAMMING</b>	
6.1 - Level one programming (ON-OFF functions)	7
6.2 - Level two programming (adjustable parameters)	8
<b>Chapter 7 - TROUBLESHOOTING... (troubleshooting guide)</b>	10
<b>Chapter 8 - FURTHER INFORMATION</b>	
8.1 - Total deletion of control unit memory	11
8.2 - Other functions	11
8.3 - Adding or removing devices	12
8.3.1 - Bluebus Input	12
8.3.2 - Photocells	12
8.3.3 - MOTB digital selector and proximity reader for MOMB transponder cards	13
8.3.4 - STOP Input	13
8.4 - Diagnostics	13
8.4.1 - Signals of control unit	13
8.4.2 - Flashing light signals	14
<b>PRODUCT DISPOSAL</b>	15
<b>TECHNICAL CHARACTERISTICS OF THE PRODUCT</b>	15
<b>Declaration of Conformity appendix I (removable appendix)</b>	16
<b>Operation manual (removable appendix)</b>	17
<b>Maintenance schedule (removable appendix)</b>	19
<b>PICTURES</b>	I - XIV
<b>EC DECLARATION OF CONFORMITY and declaration of incorporation of "quasi-machine"</b>	XVI

## 1 WARNINGS AND GENERAL PRECAUTIONS

### 1.1 - Safety instructions

- **CAUTION!** – This manual contains important instructions and warnings for personal safety. Incorrect installation could cause serious physical injury. We recommend that you read this entire manual with care before starting any work. If in doubt, do not install the product and contact the Nice technical assistance department.
- **CAUTION!** – Important instructions: keep this manual in a safe place to enable future product maintenance and disposal operations.

### 1.2 - Installation warnings

- Before commencing installation, check that the product is suitable for the intended kind of use (see paragraph 3.1 and 3.2). If not suitable, do NOT proceed with installation.
- The contents of this manual refer to a standard system such as that shown in fig. 1. Considering the risk situations that may arise during installation phases and use of the product, the automation must be installed in observance of the following warnings.
  - On the power line to the system, install a device for disconnection from the power mains with a gap between contacts that assures complete disconnection in the conditions of overvoltage category III.
  - All product installation and maintenance operations must be performed with the automation disconnected from the power mains. If the power disconnect device is not visible from the location of the automation, before starting working, a suitable notice must be affixed on the power disconnect device stating "WARNING! MAINTENANCE IN PROGRESS".
  - Connect the product to an electric power line equipped with an earthing system.
  - During installation, handle the automation with care to avoid crushing, impact, dropping or contact with liquids of any type. Never place the product near sources of heat or expose to naked flames. This may damage product components and cause malfunctions, fire or hazardous situations. If this occurs, suspend installation immediately and contact the Nice Service Centre.
  - Never make modifications to any part of the product. Operations other than as specified can only cause malfunctions. The manufacturer declines all liability for damage caused by makeshift modifications to the product.
  - This product is not designed to be used by persons (including children) whose physical, sensorial or mental capacities are reduced, or with lack of experience or skill, unless suitable instructions regarding use of the product have been provided by a person responsible for safety.
  - The product may not be considered an efficient system of protection against intrusion. If an efficient protection system is required, the automation must be integrated with other safety devices.
  - Do not allow children to play with fixed control devices. Keep remote control devices out of reach of children.
  - SBAR cannot be used before the commissioning procedure as specified in chapter 5 "Testing and commissioning".
  - The product's packaging materials must be disposed of in full compliance with local regulations.

### 1.3 - Special warnings related to European Directives applicable to the product

- **"Construction Products" Directive:**

Special warnings related to 89/106/EEC "Construction Products" Directive and subsequent modification 98/38/EEC applicable to the product:

  - Complete installation of this product, as described in this instruction manual and for certain types of use (for example excluding exclusive use for vehicles) may class it in the field of application of the Directive "Construction Products" 89/106/EEC and relative harmonised standard EN 13241-1.
  - Paragraph 1.3.1 specifies all installation criteria required to ensure that the product complies with the essential requirements of the directive 89/106/EEC; the installer should check and ensure that all these criteria are strictly observed.
  - Failure to observe one or more of these criteria may mean that the SBAR product may not meet all the essential requirements. **Use of the product in these situations is strictly prohibited until all the directive requirements are met; in this case, the label "ES13241-1.4870" applied on the product must be removed and the "EC declaration of Conformity" in appendix I of this manual may not be used.** As a consequence, the installer in turn becomes the manufacturer of the "automatic barrier", and must therefore observe all requirements of the Directive "Construction Products" 89/106/EEC and relative harmonised standard EN 13241-1. In this case SBAR must be considered as a "machine component" and the "Declaration of conformity" in appendix II may be used (for insertion in the technical documentation).
- **"Machinery Directive":**
  - Paragraph 1.3.1 specifies all installation criteria required to ensure that the product complies with the essential requirements of the "Machinery directive" 2006/42/EC (ex 98/37/EC). The installer should check and ensure that all these criteria are strictly observed.

- Failure to observe one or more of these criteria during installation or use may mean that the SBAR product may not meet all the essential requirements. **Use of the product in these situations is strictly prohibited until all the directive requirements are met: the “EC declaration of Conformity” in appendix I of this manual may not be used.** As a consequence, the installer in turn becomes the manufacturer of the “automatic barrier”, and must therefore observe all requirements of the Machinery Directive 2006/42/EC. The manufacturer must complete a risk assessment, which also includes the list of essential safety requirements as stated in “appendix I of the Machinery Directive”, specifying the relative solutions adopted. Note that the risk assessment is one of the documents that constitutes the automation “technical documentation”. This must be compiled by a professional installer with the possibility of using the “Declaration of Conformity” in appendix II to be compiled by the installer of SBAR.

Special warnings regarding suitability of this product in relation to the “Machinery” Directive 2006/42/EC; to be taken into consideration when the installer becomes the manufacturer of the product. SBAR is issued onto the market as a “quasi machine” and therefore constructed for incorporation in a machine or to be assembled with other machinery to produce a single “machine” in accordance with the Directive 2006/42/EC only in conjunction with the other components and in the ways as described in this instruction manual. As established in directive 2006/42/EC, this product may not be started up until the manufacturer of the machine, in which this product is incorporated, has not identified and declared as compliant with the directive 2006/42/EC.

• **“Low Voltage” Directive:**

Particular warnings concerning the suitable use of this product in relation to the 2006/95/EEC “Low Voltage” Directive:

This product meets the requirements of the “Low Voltage” Directive if used as specified in the configurations as envisaged in this instruction manual and in combination with the articles listed in the product catalogue of Nice S.p.a.

These requirements may not be guaranteed if the product is used in configurations or with other products that have not been foreseen; the use of the product is prohibited in these situations until the correspondence to the requirements foreseen by the directive have been verified by those performing the installation.

• **“Electromagnetic compatibility” Directive:**

Particular warnings concerning the suitable use of this product in relation to the 2004/108/EEC “Electromagnetic Compatibility” 2004/10/EEC:

This product has been subjected to tests regarding the electromagnetic compatibility in the most critical of use conditions, in the configurations foreseen in this instructions manual and in combination with articles present in the Nice S.p.a. product catalogue

The electromagnetic compatibility may not be guaranteed if the product is used in configurations or with other products that have not been foreseen; the use of the product is prohibited in these situations until the correspondence to the requirements foreseen by the directive have been verified by those performing the installation.

**1.3.1 - Installation criteria and special warnings related to essential requirements**

This product, if correctly installed, complies with the essential requirements as envisaged by the European Directive on “Construction Products” 89/106/EEC according to the provisions of harmonised standard EN 13241-1, as specified in **Table A**; and by the European Directive on “Machinery” 2006/42/EC.

**Caution!** – If SBAR is intended for exclusively vehicle transit, it would be excluded from the field of application of EN 13241-1; in this case, compliance with some of the requirements stated in Table A may not be compulsory.

Transit may be considered “exclusively vehicle” when there is an express prohibition for other types (for example pedestrians), such as by using adequate signs and, if other types are required, there is adequate space in the immediate vicinity.

• **Release of hazardous substances:**

The product does not contain and/or release hazardous substances in conformity with the provisions of the standard EN 13241-1, point 4.2.9 and according to the list of substances stated in the web site of the European Community \*: [http:// europa.eu.int/comm/enterprise/construction/internal/dangsub/dangmain\\_en.htm](http://europa.eu.int/comm/enterprise/construction/internal/dangsub/dangmain_en.htm)

(\*) Last update: 17/03/2003

**Special warning to guarantee compliance with the requirement** – It is essential that also all other materials used in installation, such as electric cables, comply with this requirement

• **Resistance to wind load:**

**Table B** specifies resistance of the pole supplied to the differential pressure of the wind. The tests were performed with the pole fitted with the impact protection profile; other accessories may increase the exposed surface and thus reduce the resistance to wind load.

• **Safe opening for vertically moving doors:**

The product does not cause uncontrolled movements or dropping of the pole in the event of a fault on a single component of the suspension or balancing (spring) system.

**Special warnings to guarantee compliance with the requirements:**

- Perform installation in strict observance of all instructions in chapters “3 - Installation” and “5 - Testing and Commissioning”

- Ensure that a maintenance schedule is drawn up (for example, by using a “Maintenance indicator” connected to the FLASH output associated with the relative function - see Table 7); in which, all instructions in the chapter “Maintenance Schedule” must be strictly followed.

• **Mechanical strength and stability of the product:**

The product is designed and constructed to ensure that, during normal use, all forces applied, impact and normal wear will not damage or impair mechanical performance.

**Caution:** See specifications for the requirement “Safe opening for vertically moving doors”.

• **Manoeuvring forces for power-operated doors/gates:**

The operating forces applied by the pole in relation to the risks of crushing and impact are protected by means of one of the three following methods:

**1 For operation with “hold-to-run” controls:** as specified in EN 12453:2000, point 5.1.1.4. In this case the control button must be located in sight of the automation, and if accessible by the public, the control must not be available to the latter, for example protected by means of a key-operated selector switch.

**2 For “semi-automatic” operating mode:** by force limitation as specified in EN 12453:2000, points 5.1.1.5 and 5.1.3.3.

**3 For “automatic” operating mode:** by force limitation as specified in EN 12453:2000, points 5.1.1.5 and 5.1.3; in this case installation is compulsory of at least one pair of photocells as shown in **fig. 1**.

**Specific warnings for “semi-automatic” and “automatic” operating modes:** the type tests for checking efficiency of force limitation were performed with the Force setting at the maximum level (Force = 8) and Speed setting at the maximum value (Speed = 5 (100%); with the pole assembled as per the instructions and fitted with the “impact protection profile” above and below the pole and with the accessory “indicator lights” XBA4 inserted on the upper impact protection profile.

**Special warning to guarantee compliance with the requirement:** See specifications for the requirement “Safe opening for vertically moving doors”.

**TABLE A - Essential requirements for CE marking (according to prospect ZA.1 of standard EN 13241-1)**

Essential requirements	Point of standard	Result
Resistance to water	4.4.2	NPD*
Release of hazardous substances	4.2.9	Compliant
Resistance to wind load	4.4.3	Compliant
Heat resistance	4.4.5	NPD*
Permeability to air	4.4.6	NPD*
Safe opening for vertically moving doors	4.2.8	Compliant
Definition of the geometry of glass components	4.2.5	NPD*
Mechanical strength and stability	4.2.3	Compliant
Manoeuvring forces for power-operated doors/gates	4.3.3	Compliant
Durability of resistance to water, heat resistance and permeability to air	4.4.7	NPD*

\* NPD = No Performance declared, when the product does not offer this performance, for example “Permeability to air”, or when the requirement is not applicable, such as “Definition of the geometry of glass components”.

**TABLE B**

Pole type	Class to EN 12424	Maximum wind speed	Type of phenomena according to the Beaufort scale
XBA19 pole	5 (> 1000 Pa)	389 m/s (108 km/h)	Storm

## 2 PRODUCT DESCRIPTION AND INTENDED USE

SBAR is an electromechanical road barrier for residential use; it controls opening and closing of a road transit point with widths up to 3 metres.

**CAUTION! – Any uses other than those specified herein or in environmental conditions other than as stated in this manual are to be considered improper and are strictly prohibited!**

SBAR is an electromechanical gearmotor with a 24 V motor, with optional flashing light signal (XBA7) and electric limit switch system. The control unit is set up for connected to devices belonging to the Nice Opera system and connection to the solar power system “Solemyo” (see paragraph 4.10.3).

SBAR runs on electric energy and in the event of a power failure the pole can be released and moved manually. Alternatively the buffer battery model PS124 can be used (optional accessory - see paragraph 4.10.2), which guarantees a number of automation manoeuvres in the first few hours of power failure. To prolong this period or extend the number of manoeuvres, the Stand by function should be enabled (see table 6).

SBAR is also designed for installation of the pole lights, mod. XBA4 (accessory - see paragraph 4.8).

## 3 INSTALLATION

### 3.1 - Preliminary checks for installation

Before proceeding with installation, check the condition of the product components, suitability of the selected model and conditions of the intended installation environment.

- Ensure that all material used is in perfect condition and suitable for use.
- Ensure that all product application limits can be observed (see paragraph 3.2).
- Ensure that the selected installation environment is compatible with the overall dimensions of the product (fig. 2).
- Ensure that the selected surfaces for barrier installation are solid and guarantee a stable fixture.
- Make sure that the fixing zone is not subject to flooding. If necessary, mount the barrier raised from the ground.
- Ensure that the space around the barrier enables easy and safe completion of manual manoeuvres.
- Ensure that there are no obstacles along the pole trajectory which prevent the opening and closing manoeuvres.
- Ensure that each device to be installed is in a sheltered location and protected against the risk of accidental impact.

### 3.2 - Product application limit

Before installing the product, ensure that all values specified in the chapter “Technical product specifications” and maximum cycle frequency as stated in **Table 1** are compatible with the intended use.

- Ensure that the estimated durability (see paragraph 3.2.1) is compatible with the intended use.
- Ensure that all limits, conditions and warnings in this manual can be observed.

Product Type	Maximum speed	Maximum work cycles per hour	Maximum consecutive work cycles
SBAR with XBA19 pole, impact protection rubber XBA13, without accessories	V5	100	50
SBAR with XBA19 pole, impact protection rubber XBA13 and lights mod. XBA4	V4	80	40

#### 3.2.1 - Product durability

The lifetime is the average economic duration of the product. The value of lifetime is strongly influenced by the intensity of the manoeuvres, i.e. the sum of all factors that contribute to product wear (see **Table 2**).

To estimate the lifetime of your automation, proceed as follows:

01. Add the values of the items in **Table 2** regarding the system conditions;
02. In **Graph 1** from the value obtained above, trace vertical line until it intersects the curve; from this point trace a horizontal line until it intersects the line of the “manoeuvre cycles”. The obtained value is the estimated lifetime of your product.

The lifetime values specified in the graph are only obtainable if the maintenance schedule is strictly observed (see chapter “Maintenance schedule”). The estimation of lifetime is made on the basis of design calculations and the results of tests performed on prototypes. As it is only an estimation, it does not represent any form of guarantee on the effective lifetime of the product.

TABLE 2

	Severity Index
Pole with lights mod. XBA4	15 %
Ambient temperature above 40°C or below 0°C	15 %
Presence of dust or sand	10 %
Presence of saline mist	10 %
Interruption of manoeuvre via Foto > 10%	15 %
Interruption of manoeuvre via Alt > 10%	25 %
Force equal to 5 or 6	10 %
Force equal to 7 or 8	10 %
V3 and V4 speed	5 %
Speed V5	20 %

GRAPH 1

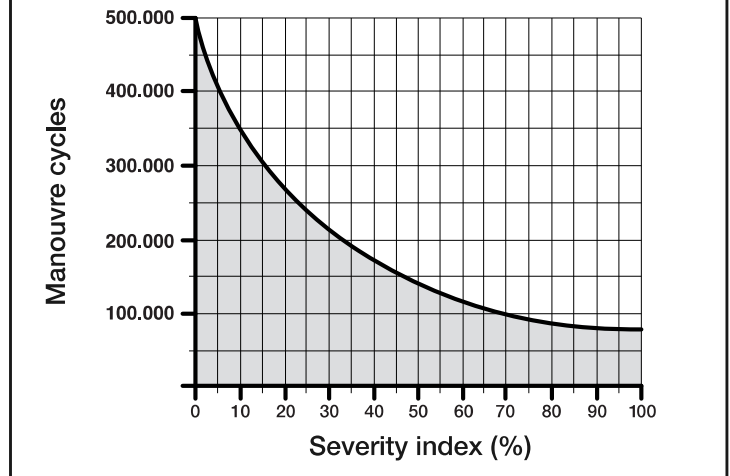

**Example of calculating lifetime of road barrier SBAR (refer to Table 2 and Graph 1):**

SBAR with lights XBA4 (severity index of 15%) - Presence of saline mist (severity index of 10%): **Total severity index = 25%**

**The estimated durability is approx. 240,000 manoeuvre cycles.**

### 3.3 - Typical system

**Fig. 3** shows the components in the product pack:

- [a] - road barrier with built-in control unit
- [b] - pole support
- [c] - pole plug
- [d] - 2 pole joining brackets
- [e] - metal hardware (screws, washers, etc. keys for manual locking and release of the pole)
- [f] - fixing bolts
- [g] - photocell box
- [h] - foundation plate

**Fig. 1** shows an example of an automation system set up with Nice components. With reference to the typical standard layout in **fig. 1**, locate the approximate position for installation of each component envisaged in the system.

**CAUTION! – In general, position the ends of the ducting used for electrical cables in the vicinity of the points envisaged for fixture of the various components. Note: The ducting serves to protect electric cables and prevent accidental damage, such as in the case of impact.**

**The barrier is factory set for the closing manoeuvre to the left;** in this phase, it is important to decide whether the opening direction of the pole is to be inverted. **If Closure to the right is required, see paragraph 3.3.1.**

Prepare the electrical cables needed for your system, referring to **fig. 1** and “**Table 3 - Technical specifications of electrical cables**”.



**TABLE 3 - Technical specifications of electrical cables (Fig. 1)**

Connection	Cable type	Maximum admissible length
<b>A:</b> Mains POWER SUPPLY cable	cable 3 x 1,5 mm <sup>2</sup>	30 m (note 1)
<b>B:</b> Cable for BlueBus devices	cable 2 x 0,5 mm <sup>2</sup>	30 m
<b>C:</b> POLE LIGHTS		
<b>C:</b> KEY-OPERATED SELECTOR SWITCH cable	cables 4 x 0,25 mm <sup>2</sup>	30 m (note 2)
OPTIONAL FLASHING LIGHT	cable provided	

**IMPORTANT** – To make the connection, programming of the FLASH output must be modified (see paragraph 6.2 - Table 7)

**Note 1** – If the power cable is longer than 30 m, a cable with a larger cross-section is required (3 x 2.5 mm<sup>2</sup>) and safety earthing is necessary in the vicinity of the automation.

**Note 2** – If a MOMB transponder badge reader or MOTB digital keypad is used, a 2-wire cable is sufficient (2 x 0,5 mm<sup>2</sup>).

**CAUTION!** – The cables used must be suited to the installation environment.

### 3.3.1 - Modifying the factory settings of the Closure manoeuvre

If **Closure to the right**, is required proceed as follows:

01. Remove the cover (fig. 4);
02. Loosen the 2 screws fixing the cabinet door (fig. 4);
03. Remove the balancing screw, detaching it from the balancing lever (fig. 5 - phase A, B, C, D);
04. Remove the balancing screw support bolt (fig. 6 - A);
05. Release the gear motor (see paragraph 3.6 - fig. 6 - B);
06. Turn the balancing lever through 90° (fig. 6 - C - use a rubber mallet if required);
07. Tighten the balancing screw support bolt fully down (fig. 7);
08. Attach the balancing screw in the correct location (fig. 8 - phase A, B);
09. Lock the gear motor (see paragraph 3.6);
10. On the control unit, activate (ON) the function "Motor rotation direction" (see chapter 6 - Table 6).

Prepare the electrical cables needed for your system, referring to fig. 1 and "Table 3 - Technical specifications of electrical cables".

## 3.4 - Barrier fixture

### 3.4.1 - If the support surface already exists

[\*] The fixing surface must be perfectly smooth and flat. If the surface is in concrete, it must be at least 0.15 m thick, and must be adequately reinforced with steel cages. The concrete volume must be greater than 0.2 m<sup>3</sup> (a thickness of 0.25 m corresponds to 0.8 m<sup>2</sup>; in other words equal to a square base of approx. 0.9 m per side).

Anchoring to the concrete can be by means of 4 expansion bolts, fitted with 12 MA screws, which resist to a traction load of at least 400 Kg. If the fixing surface is in another material, the consistency must be checked and ensure that the 4 anchoring points can resist a load of at least 1000 Kg. For fixture, use 12 MA screws.

Proceed as follows:

01. Open the barrier cabinet (fig. 4);
02. Place the barrier on the fixing surface and trace the points where the slots are to be fixed (fig. 9);
03. Move the barrier and drill the traced surface points; then insert 4 expansion bolts, not supplied (fig. 10);
04. Position the barrier correctly and secure by means of the relative nuts and washers not supplied (fig. 11 - A, B).

### 3.4.2 - If the support surface does not exist

01. Dig the foundation pit to house the foundation plate, (optional accessory). For the pit dimensions, refer to the specifications at point [\*] of paragraph 3.4.1.
02. Prepare ducting for connection cables;
03. On the foundation plate, fix the 4 bolts, placing a nut on the upper side of each and one on the lower side of the plate. **Caution** – The lower nut must be tightened down to the threaded section;
04. Now cast the concrete, and before it sets, embed the foundation plate, which must be positioned flush with the surface, parallel to the pole and perfectly level (fig. 12). Wait for the concrete to set completely; in general, at least 2 weeks;
05. Remove the 4 upper nuts of the bolts;
06. Open the barrier cabinet (fig. 4);
07. Position the barrier correctly and secure by means of the relative nuts and washers supplied with the foundation plate e moved in point 04 (fig. 13 - A, B).

## 3.5 - Pole installation

### 3.5.1 - Pole support assembly

01. Insert the two plugs in the relative seats on the output motor shaft (fig. 14 - phase A and B);

02. Position the support on the output motor shaft, placing it in the "vertical pole" position and tighten the relative screws and washers fully down to secure (fig. 15 - phase A and B);
03. Position the pole cover and partially secure by means of the 4 screws supplied (fig. 16 - phase A and B).

### 3.5.2 - Pole assembly

01. Lightly grease the aluminium guide on both sides (fig. 17).
02. Perform this operation on both ends of the pole: insert the first part of impact protection rubber in the slot, through to the end of the pole; then insert the joint for the impact protection rubber (fig. 18) and repeat with all parts;
03. Position the pole plug (fig. 19):
  - A) the impact protection must be inserted by at least 1 cm;
  - B) insert the pole plug and block the plug with the screws provided;
  - C) push the upper impact protection towards the plug, making it slightly protrude and block the two impact protection cover plugs;
04. On the opposite end to that with the plug, insert the pole support plates (fig. 20);
05. Insert the pole assembly in the pole support shell, pushing it up to the end and then tighten the 4 previously inserted support screws fully down.

## 3.6 - Manually releasing and locking the gearmotor

The gearmotor can be released manually on both sides of the barrier as shown in fig. 21:

01. Rotate the key cover;
02. Insert the key supplied and turn through 180° both clockwise and anti-clockwise;
03. To lock the gearmotor, rotate the key through a further 180° in the same direction as before.

## 3.7 - Mechanical stop adjustment

01. Release the gear motor manually (see paragraph 3.6);
02. Manually move the pole through a complete Opening and Closing manoeuvre;
03. Then adjust the mechanical stop screws (Fig. 22 and 23) to align the pole vertically and horizontally;
04. Tighten down the nuts.

## 3.8 - Pole balancing

The pole needs to be balanced to establish the best balance between two factors: the weight of the pole and any accessories and the counterposed force of the balancing spring. The latter individually guarantees balancing of the pole; if this rises or lowers, proceed as described below.

01. Release the gear motor manually (see paragraph 3.6);
02. Manually move the pole to mid-travel (45°) and leave stationary. Then ensure that the pole remains still in position. If the pole tends to lift, reduce the tension of the spring, if the pole tends to drop, increase the tension of the spring. To modify spring tension, see point 04;
03. Repeat point 02 positioning the pole also at approx. 20° and approx. 70°. If the pole remains still in position, this means that balancing is correct; a slight off balance is admissible, but the pole must never move significantly.

The off-balance value is only acceptable when the force required to move the pole (measured at right angles to the pole and at 1 m from the rotation axis) on Opening, Closing and in all other positions, does not exceed half the value of the maximum torque (for this product, approx. 5 Kg at 1 m).

04. - If the pole is not correctly balanced; to balance move the pole to the maximum opening position.

- Detach the balancing spring from its seat (fig. 24) and move its anchoring point towards the centre, to reduce spring tension, or outwards to increase spring tension;

05. Lock the gear motor (see paragraph 3.6).

## 4 ELECTRICAL CONNECTIONS

**CAUTION!** – All electrical connections must be made with the unit disconnected from the mains power supply.

01. Loosen the screws of the cover (fig. 25);

02. Route the electric cables inside SBAR, starting from the base towards the control unit and routing them to the left;

03. Connect the wires of the electric power cable to the 3-contact terminal with fuse and secure the cable with the collar (fig. 26);

04. Connect the other cables as shown in the wiring diagram in fig. 27.

*Note – To facilitate cable connections, the terminals can be removed from their seats.*

### 4.1 - Description of the electrical connections

• **FLASH** = this output is programmable (see Chapter 6, paragraph 6.2 - Level 2 programming - adjustable parameters) to connect one of the following devices:

– **Flashing light**: if programmed as “flashing light” on the “FLASH” output, a NICE flashing light model “LUCY B, MLB or MLBT” with a 12 V 21 W car type lamp. During the manoeuvre it flashes at intervals of 0,5 s lit and 0,5 s off.

– **“pole open indicator” - “activated if the pole is closed” - “activated if pole is open” - “flashing light for pole lights” and “maintenance indicator”**: if programmed with one of these 5 functions on the “FLASH” output, a 24 V indicator (max. 10 W) can be connected for the following signals:

#### “Pole open indicator” function

Pole closed: Off

Pole opening: Slow flashing light

Pole closing: Quick flash light

Pole open (not closed): lit

#### “Active if pole closed” function

Pole closed: On

All other cases: Off

#### “Active if pole open” function

Pole open: On

All other cases: Off

#### Function “flashing light for pole lights”

The indicator light or pole lights indicate execution of the manoeuvre in progress by flashing constantly at regular intervals (0.5 sec on; 0.5 seconds off)

#### Function “Maintenance indicator”

- indicator lit on for 2 seconds at the start of the opening manoeuvre = number of manoeuvres less than 80%

- flashing light indicator during execution of the entire manoeuvre = number of manoeuvres between 80 and 100%

- indicator constantly flashing = number of manoeuvres greater than 100%.

– **Suction cup**: a 24V max 10W suction cup can be connected (versions with electromagnet only, without electronic devices). When the pole is closed, the suction cup is activated to lock the pole in place. During the opening and closing manoeuvre it is deactivated.

– **Electric block**: a 24 V max 10 W electric block with latch can be connected (versions with electromagnet only, without electronic devices). During the opening manoeuvre, the electric lock is activated and remains active to free the pole and perform the manoeuvre. In the closing manoeuvre ensure that the electric block re-engages mechanically.

– **Electric lock**: a 24 V max 10 W electric lock with latch can be connected (versions with electromagnet only, without electronic devices). At the start of the opening manoeuvre, the electric lock is activated for a short period to release the pole and complete the manoeuvre. In the closing manoeuvre ensure that the electric lock re-engages mechanically.

• **BLUEBUS** = this terminal enables the connection of compatible devices; all are connected in parallel with just two wires conveying the electric power and communication signals. For further details see Chapter 8.

• **STOP** = input for devices that block or shut down the manoeuvre in progress; by setting the input accordingly, it is possible to connect Normally Closed type contacts, Normally Open contacts, constant resistance or optical devices. For further details see chapter 8.

• **PP** = input for devices control movement in Step-Step mode, enabling the connection of Normally Open contacts.

• **OPEN** = input for devices which control only opening manoeuvre. NO contacts can be connected to this input.

• **CLOSE** = input for devices which control only closing manoeuvre. NO contacts can be connected to this input.

• **AERIAL** = input for connection of the aerial for the radio receiver (the aerial is incorporated on LUCY B, MBL, MLBT).

**IMPORTANT!** – NEVER CONNECT DEVICES OTHER THAN THOSE SPECIFIED.

### 4.2 - Initial start-up and electrical connections

**CAUTION!** – The final connection of the automation to the electrical mains must be made exclusively by a qualified skilled technician, in observance of current local standards.

Connect the control unit to an electric power line equipped with an earthing system. The power supply line must be protected by suitable magneto-thermal and differential switches. Envisage a mains disconnect device, with a contact opening distance that ensures complete disconnection in the conditions of overvoltage category III, or envisage a plug and socket system.

After powering up the control unit, perform the following checks:

• Make sure that the “Bluebus” LED flashes quickly for a few seconds and then regularly with a frequency of about one flash per second.

• If photocells are present, check that the leds on the latter also flash (both on TX and RX elements); the type of flash is not significant as this depends on other factors.

• Check that the device connected to the FLASH output is off (with factory setting).

• Ensure that the light on the control unit is switched off.

If the above conditions are not satisfied, switch off the power supply to the control unit and check the electrical connections previously made.

For more useful information see also chapter “7 Troubleshooting”.

### 4.3 - Pre-set functions

The control unit is equipped with a series of programmable functions, which are factory set with the most commonly used values. These values can be modified at any time: See chapter 6.

### 4.4 - Recognition of the connected devices

After the initial power-up, the control unit must be able to recognise the devices connected on the inputs “Bluebus” and “Stop”.

**CAUTION!** – The learning phase must be performed even if no device is connected to the control unit.

To indicate whether this operation is necessary, leds “L1” and “L2” on the control unit emit a number of flashes.

01. Press and hold down “Open” and “Set” keys at the same time.

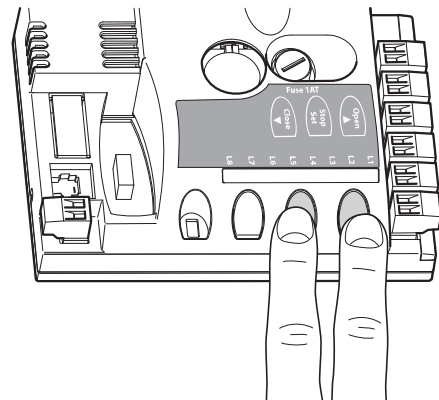

02. Release the keys when LEDs L1 and L2 start flashing quickly (after approx. 3 seconds).

03. Wait a few seconds for the control unit to complete the device learning phase. At the end of this phase, the “Stop” led must be lit and leds “L1” and “L2” must turn off (leds “L3” and “L4” may start flashing to indicate that the positions have not be learnt).

This procedure must be repeated in the case of modifications to the devices connected to the terminals BlueBus and Stop; for example, after connecting a new device to the control unit.

### 4.5 - Recognition of limit positions on opening and closing

After learning the connected devices, the control unit also has to learn the positions of the mechanical stops. In this phase, the pole travel distance is read, measured from the closing mechanical stop to the opening mechanical stop.

01. Manually release the gearmotor (see chapter 3.6) and manually position the pole at approx. 45° (mid-travel);

02. Lock the gear motor (see paragraph 3.6);

03. Press and hold down "Close" and "Set" keys at the same time.

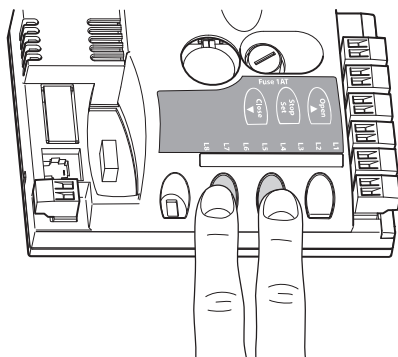

04. Release the keys when the manoeuvre starts (after approx. 3 seconds);

05. Wait a few seconds for the control unit to complete the position learning phase: pole closing, opening and closing.

06. Press "Open" for the pole to run a complete Opening manoeuvre.

07. Press "Close" for the pole to run a complete Closing manoeuvre.

During these manoeuvres, the control unit memorises the force required to complete these manoeuvres.

**CAUTION!** – The learning phases **must never be interrupted**. If this occurs, the entire learning procedure must be repeated.

At the end of the learning phase, if leds "L3" and "L4" flash, this means that there is an error. The phase for learning the mechanical stops can be repeated at any time, also after installation (for example, if the position of a mechanical stop is moved).

**IMPORTANT** – The deceleration points are calculated automatically by the control unit; after the position search phase, at least 2 or 3 complete manoeuvres must be performed before that control unit can correctly calculate the points of deceleration.

#### 4.6 - Pole movement check

After learning the devices and completing the 2-3 manoeuvres to calculate deceleration, a number of Opening and Closing manoeuvres should be performed to ensure correct pole movement.

01. Press "Open" to activate an Opening manoeuvre; ensure that the pole starts to decelerate before reaching the opening position;

02. Press "Close" to activate a Closing manoeuvre; ensure that the pole starts to decelerate before reaching the closing position;

03. Make sure that the (optional) LED flashing light flashes at regular intervals (0.5 sec on, 0.5 sec off) during a manoeuvre.

04. Run a number of Opening and Closing manoeuvres to ensure that there are no points of increased friction or malfunctions.

**CAUTION** – If the manoeuvre starts from a position different from that of one of the mechanical stops (opening or closing), it is performed at low speed.

#### 4.7 - Connecting a radio receiver

The control unit is fitted with a SM type connector for connection of a radio receiver (optional accessory) model SMXI, SMXIS, OXI or OXIT and similar.

To insert the radio receiver, disconnect the control unit from the power mains and insert the receiver as shown in fig. 28.

Table 4 shows the actions performed by the control unit according to the outputs activated or the commands sent from the radio receiver.

#### 4.8 - Connecting the pole lights (optional accessory)

01. Move the pole to the vertical position;

02. Unscrew the 4 screws that hold the pole cover (fig. 29);

03. Remove the pole temporarily;

04. Insert the grommet in the pre-drilled hole for cable routing (fig. 30 - A, B);

05. Route the lights cable through the impact protection rubber profile, using a guide to facilitate attachment if necessary (fig. 31 - A, B);

06. If necessary, shorten the length of the lights cable: cuts may only be made at the points bearing the relative mark. After cutting, the plug at the cut end must be moved to seal off the new end;

07. Insert the cable first through the hole on the pole support and then through the hole on the cabinet (fig. 32 - A, B, C); **Caution** – Leave a little extra cable in the pole support, to enable pole rotation through 90° without tensioning the cable;

08. Connect the lights cable to the FLASH terminal on the control unit: see diagram in fig. 27;

09. Position and secure the connector in the slot on the pole (fig. 32 - D);

10. Insert the pole and secure with its cover, tightening the 4 screws fully down and taking care not to pinch the wiring cable (fig. 33).

#### 4.9 - Connecting the LED flashing light mod. XBA7 or LED traffic light mod. XBA8 (optional accessories)

On the cover of the barrier a LED flashing light mod. XBA8 may be fitted. The operating mode of this flashing light may be modified through the Oview pro-

TABLE 4

#### SMXI, SMXIS Receiver

output	description
Output no. 1	Step by step
Output no. 2	Partial Open (opens to approx. 45%; value programmable with Oview, see paragraph 4.10.1)
Output no. 3	Open
Output no. 4	Close

#### OXI receiver, OXIT programmed in "Extended Mode II"

Command	description
Command no. 1	Step by step
Command no. 2	Partial Open (opens to approx. 45%; value programmable with Oview, see paragraph 4.10.1)
Command no. 3	Open
Command no. 4	Close
Command no. 5	Stop
Command no. 6	Apartment block Step by Step
Command no. 7	Step-Step High priority (controls also if automation is blocked)
Command no. 8	Unblock + Open
Command no. 9	Unblock + Close
Command no. 10	Open and block automation
Command no. 11	Close and block automation
Command no. 12	Block automation
Command no. 13	Release automation
Command no. 14	Courtesy light timer on
Command no. 15	Courtesy light on-off

grammer or with suitable programmes of the control unit. For further information, refer to the instruction manual for the product.

#### 4.10 - Connection of other devices

SBAR also enables power supply to external devices (a radio receiver or key-operated selector switch lighting) by receiving power from the control unit: for the type of connection, see Fig. 34.

The power supply voltage is 24 Vdc, -30%/+50%, with maximum available current 100 mA.

##### 4.10.1 - Programming unit Oview

The use of the programming unit Oview enables complete and rapid management of installation, maintenance and troubleshooting of any malfunctions of the whole automation system. Oview can be connected to SBAR by means of the BusT4 connector on the control unit.

To access the BusT4 connector, open the cover of SBAR and insert the connector in its seat (fig. 35).

In general, Oview can be positioned at a maximum distance of 100 m of cable from the control unit; it can be connected to multiple control units simultaneously (max. 16) and can also remain connected during normal operation of the automation; to exceed these limits, observe the warnings in the Oview instruction manual and the Oview System Book system manual. If a OXI type radio receiver is present in the control unit, Oview enables access to the parameters of the transmitters memorised in this receiver. For detailed information, refer to the instruction manual of the Oview programmer or the "SBAR" function datasheet also available on the website [www.niceforyou.com](http://www.niceforyou.com).

##### 4.10.2 - Buffer battery mod. PS124 (accessory)

In the event of a mains power failure, SBAR can also be powered by a buffer battery model PS124. To install and connect the battery, proceed as follows:

**Caution!** – The electric connection of the battery to the control unit must only be made after completing all installation and programming phases, as the battery constitutes an emergency power supply.

01. Connect the relative cable of the buffer battery and position the battery as shown in fig. 36;

03. Remove the membrane on the control unit (fig. 37);

04. Disconnect the mains power and fit the connector as shown in fig. 38.

##### 4.10.3 - Solemyo System (photovoltaic supply)

SBAR is designed to be powered with the "Solemyo SYKCE" photovoltaic system. To connect IT to the control unit, use the socket that is normally used for the buffer battery (see paragraph 4.10.2).

#### IMPORTANT!

- When SBAR is powered by the "Solemyo" system, it MUST NOT BE POWERED at the same time from the electrical mains.

- Due to the limited solar power available, depending on the installation location and time of year, SBAR can perform a maximum number of manoeuvres per day. Before installing the Solemyo system, check in the relative instruction manual whether the maximum number of pos-

sible manoeuvres is compatible with the intended use.

- **The Solemyo system can only be used efficiently if the control unit is active and set with the Standby function set to "All" mode (only possible using the Ovview programmer).**

## 5 TESTING AND COMMISSIONING

These are the most important phases of automation set-up for ensuring maximum system safety. The test can also be performed as a periodic check of automation devices. Testing and commissioning of the automation must be performed by skilled and qualified personnel, who are responsible for the tests required to verify the solutions adopted according to the risks present, and for ensuring observance of all legal provisions, standards and regulations, and in particular all requirements of the standard EN 12445, which establishes the test methods for checking automations for doors and barriers. All these operations must be performed under the direct supervision of the head installer, i.e. the person who enters his/her name and signature in box N°1 of the declaration of conformity (see appendix I).

The additional or optional devices must undergo a specific test for functionality and correct interaction with SBAR.

### 5.1 - Testing

The sequence of operations to be performed for testing refers to a standard system (fig. 1) classed for "untrained users" and the automation activation set to "automatic control" which envisages, as a minimum protection level of the primary edge, device types C (force limitation - see standard EN 12445) combined with device types D (presence detectors, e.g. photocells). Bearing in mind that this type of use is among the most intensive, the same testing sequence can be effectively implemented in less intensive conditions.

- 1 Ensure that all specifications in this manual have been observed, with special reference to the chapter "1 Safety Instructions".
- 2 Check correct balancing of the pole, see paragraph 3.8.
- 3 Check correct operation of the manual release, see paragraph 3.6.
- 4 Using the transmitter or key-operated selector switch, perform tests of opening, closing and stopping the barrier, and ensure that pole movement corresponds to specifications. Test several times to check for pole movement and any defects in assembly or adjustment and any possible points of friction.
- 5 Check operation of all system safety devices one at a time (photocells, sensitive edges, etc.). Each time a device is activated the "Bluebus" LED on the control unit must flash rapidly twice to confirm acknowledgement of the event.
- 6 Check correct operation of the photocells as follows: depending on whether one or two pairs of photocells have been installed, one or two parallelepipeds in rigid material are required (e.g. wooden panels) with the measurements 70 x 30 x 20 cm. Each parallelepiped must have three sides, one for each size, in reflective material (e.g. mirror or white gloss paint) and three sides in opaque material (e.g. black matt paint). To test the photocells positioned at 50 cm from the ground, the parallelepiped must be placed on the ground or raised at 50 cm in the case of photocells placed at 1 m from the ground.

When testing one pair of photocells, the test specimen must be positioned exactly at the centre of the pole with the 20 cm sides facing the photocells and moved along the entire length of the pole (fig. 39).

When testing two pairs of photocells, the test must first be performed individually for each pair of photocells, using one test specimen, and then repeated using two test specimens.

Each test specimen must be positioned laterally with respect to the centre of the pole, at a distance of 15 cm sides and then moved along the entire length of the pole (fig. 40).

During these tests, the test specimen must be read by the photocells in any position along the entire length of the pole.

- 7 Ensure there is no interference between the photocells and other devices, by intercepting the optic axis joining the two photocells by means of a cylinder (diameter 5 cm, length 30 cm, fig. 41): pass the cylinder first close to the TX photocell, then close to the RX and lastly at the centre between the two. Ensure that in all cases the device engages, changing from the active status to alarm status and vice versa, and that the envisaged action is generated in the control unit (for example movement inversion in the *Closing* manoeuvre).
- 8 **Check protection against the risk of lifting:** on automations with vertical movement, it must be ensured that there is no risk of lifting. This test can be performed as follows: hang a weight of 20 kg mid-way along the pole (for example, a sack of gravel), activate an Opening manoeuvre and ensure that during operation the pole does not exceed the height of 50 cm from the closing position. If the pole exceeds this height, reduce the motor force (see chapter 6 - Table 7).
- 9 If hazardous situations generated by the moving poles are protected by means of impact force limitation, measure the force as specified in the standard EN 12445. If motor force control is used as auxiliary function with the system for reduction of impact force, test and identify the setting that obtains the best results.

**10 Check efficiency of the release system:** place the pole in the Closing position and manually release the gearmotor (see paragraph 3.6) ensuring that there is no difficulty with this procedure. Ensure that the manual force required to move the pole on opening is no greater than 200 N (approx. 20 Kg); the force is measured perpendicular to the pole and at 1 m from the rotation axis. Lastly, ensure that the key required for manual release is available in the vicinity of the automation.

**11 Power supply disconnection system check:** by using the power disconnect device, and disconnecting any buffer batteries, ensure that all leds on the control unit are off and that the pole remains stationary when any commands are sent. Check efficiency of the locking device to prevent inadvertent and/or unauthorised reconnection.

### 5.2 - Commissioning

**Commissioning can only be performed after positive results of all test phases. Partial or "makeshift" commissioning is strictly prohibited.**

- 1 Compile and provide the automation owner with the "**CE Declaration of conformity - Appendix I**", at the end of this manual, in the removable section.
- 2 Compile and provide the automation owner with the form "**Operation Manual**" at the end of this manual, in the removable section.
- 3 Compile the form "**Maintenance schedule**" containing all maintenance instructions for all devices in the automation and forward it to the owner. In the case of SBAR, this form is present at the end of this manual, in the removable section.
- 4 Before commissioning the automation, ensure that the owner is adequately informed of all associated risks and hazards.
- 5 Permanently affix on the pole the label in the pack regarding the gearmotor manual release and locking operations.
- 6 ONLY for installations NOT IN CONFORMITY with the criteria stated in chapter 1.3.1 of this manual: produce the technical documentation of the automation, which must include the following documents: an overall drawing of the automation, the wiring diagram of all connections made, an assessment of all risks present and relative solutions adopted (see forms to be compiled on the website [www.niceforyou.com](http://www.niceforyou.com)), declarations of conformity of manufacturer of all devices used (for SBAR see appendix II) and the declaration of conformity compiled by the installer.

Affix a dataplate on the barrier, specifying at least the following data: type of automation, name and address of manufacturer (responsible for commissioning), serial number, year of construction and CE mark.



# 6 CONTROL UNIT PROGRAMMING

The control unit has 3 keys **OPEN (▲)**, **STOP (Set)**, **CLOSE (▼)** that can be used both for controlling the unit during testing and for programming the available functions.

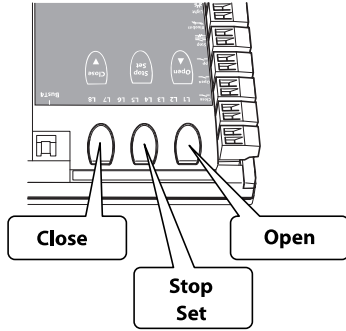

The programmable functions available are divided into 2 levels and their relative operating status is displayed by means of the 8 LEDs (L1...L8) on the control unit (LED lit = function active; LED off = function not active).

**Programming keys:**

**OPEN (▲):** the "OPEN" key enables control of pole opening or can be used, during programming, to move the programming point up.

**STOP (Set):** the "STOP" key enables the user to stop the manoeuvre;

if pressed for more than 5 seconds, it enables entry to programming mode. **CLOSE (▼):** the "CLOSE" key enables control of pole closing or can be used, during programming, to move the programming point down.

**CAUTION! – During a manoeuvre (Open or Close) all three keys have the STOP function: all manoeuvres in progress are stopped.**

## 6.1 - Level one programming (ON-OFF functions)

All level 1 functions are set by default to "OFF" and may be modified at any time as explained in Table 5. To check the value corresponding to each LED see Table 6.

**IMPORTANT –** The programming procedure has a maximum interval of 10 seconds admissible between the activation of one key and the next. When this time interval elapses, the procedure quits automatically, saving the changes made up until that time.

**TABLE 5 - Programming procedure (first level functions)**

<b>01.</b> Press and hold down the "Set" key for approx. 3 seconds;	3 s
<b>02.</b> Release the key when LED L1 starts flashing;	L1
<b>03.</b> Press keys "▲" or "▼" to move from the flashing led to the led associated with the function to be modified;	or
<b>04.</b> Press "Set" to change the status of the function: (short flash = OFF; long flash = ON)	SET
<b>05.</b> Wait 10 seconds (maximum time) to exit the programming mode.	10 s

*Note – During this procedure, points 03 and 04 need to be repeated when programming other functions to "ON" or "OFF" during the phase itself.*

**TABLE 6 - First level functions**

LED	Description	Example
<b>L1</b>	<b>Automatic closure</b>	This function performs automatic closure of the pole after the programmed pause time. Factory setting: 30 seconds. Value programmable from 5 to 200 seconds.
<b>L2</b>	<b>Reclose after photo</b>	This function enables the pole to remain in Opening position for the time required for transit. When the function is active, operation depends on the parameter set in the function "Automatic closure": <ul style="list-style-type: none"> <li>• with "Automatic closure" active, the Opening manoeuvre stops immediately after the photocells are disengaged and the Closure manoeuvre starts after 5 seconds.</li> <li>• with "Automatic closure" not active, the pole always reaches the maximum Opening position (even if the photocells are disengaged beforehand) and Closure starts after 5 seconds.</li> </ul>
<b>L3</b>	<b>Always close</b>	This function is useful in the event of a power failure, even brief. In fact if this function is active(ON), when power is restored, the control unit detects the pole as open and starts Closure. For reasons of safety the Closure manoeuvre is preceded by a 3-second pre-flashing interval.
<b>L4</b>	<b>Stand by</b>	The Stand-by function allows consumptions to be reduced. If active, 1 minute after the end of the manoeuvre, the control unit turns off the "Bluebus" output (connected devices) and all the LEDs apart from the Bluebus LED which will flash more slowly. When the control unit receives a command normal operation is restored. When using SBAR with the Solemyo system, a longer Stand By mode must be set. This operation is performed using the Oview programmer.
<b>L5</b>	<b>Deceleration long</b>	This function enables the user to double the space for starting deceleration, both in Opening and Closing. If the function is deactivated, deceleration is short.
<b>L6</b>	<b>Pre-flash</b>	This function activates a pause of 3 seconds between activation of the flashing light and the start of a manoeuvre.
<b>L7</b>	<b>Sensitivity</b>	When this function is set to "ON" the level of control unit sensitivity in obstacle detection can be increased considerably. If used as a means to read the "impact force" of the motor, the values "speed" and "motor force" must be set accordingly in the level 2 menu.
<b>L8</b>	<b>Direction of motor rotation</b>	This parameter enables inversion of the direction of motor rotation to enable barrier installation on the right; the factory setting is "OFF" (standard motor rotation – pole closure on left). <p><b>Important</b> – If the function is activated, the Opening and Closing positions must be memorised again (Paragraph 4.5).</p>

## 6.2 - Level two programming (adjustable parameters)

All level 2 parameters are set by default as highlighted in grey in Table 7, and may be modified at any time as explained in Table 8.

The parameters can be set on a scale from 1 to 8. To check the value corresponding to each LED see Table 7.

**IMPORTANT –** In the programming procedure, the maximum time interval that can elapse between activation of one key and the next is 10 seconds. When this time elapses, the procedure terminates automatically, memorising the modifications made up until then.

TABLE 7 - Second level functions

Input LED	Parameter	LED (level)	Value	Description
L1	Time Pause	L1	5 seconds	Sets the pause time, i.e. the time that passes between the end of an opening manoeuvre and the start of an automatic closing manoeuvre. This parameter is only effective if the "automatic Closure" is active.
		L2	10 seconds	
		L3	20 seconds	
		L4	40 seconds	
		L5	60 seconds	
		L6	80 seconds	
		L7	120 seconds	
		L8	200 seconds	
L2	Function Step by step	L1	Open – stop – close - stop	Sets the sequence of commands associated with the input or the radio control: "Step by step".
		L2	Open – stop – close - open	
		L3	Open – close – open - close	
		L4	Apartment block (more than 2 sec. generates Stop)	
		L5	Apartment block 2 (less than 2 sec. generates partial opening).	
		L6	Step by step 2	
		L7	Hold-to-run	
		L8	Opening in semi-automatic mode, closing in dead man mode	
L3	Speed Motor	L1	Speed 1 (30% - slow)	Sets the motor speed during normal travel.
		L2	Speed 2 (47%)	
		L3	Speed 3 (65%)	
		L4	Speed 4 (82%)	
		L5	Speed 5 (100%) - fast	
		L6	Open V3, Close V2	
		L7	Open V4, Close V3	
		L8	Open V5, Close V4	
L4	Output FLASH	L1	Pole Open Indicator Function (24 V - 10 W)	Selects the type of device connected to the FLASH output. <b>Important!</b> – If the programmed setting is modified, check the type of voltage of the new device connected to the FLASH terminal and ensure that it corresponds to the type of voltage of the selected programming level.
		L2	Active if pole closed (24 V - 10 W)	
		L3	Active if pole open(24 V - 10 W)	
		L4	Flashing light(12 V - 21 W)	
		L5	Flashing light for pole lights (24 V - 10 W) - always flashes	
		L6	Electric lock(24 V - 10 W)	
		L7	Suction cup(24 V - 10 W)	
		L8	Maintenance indicator (24 V - 10 W)	
L5	Motor force on opening	L1	Force 1 (low)	Adjusts the motor force control system to adapt it to the weight of the pole during the opening manoeuvre and consequently the sensitivity of obstacle detection. <b>Note</b> – The force is acquired automatically during execution of the first two manoeuvres.
		L2	Force 2	
		L3	Force 3	
		L4	Force 4	
		L5	Force 5	
		L6	Force 6	
		L7	Force 7	
		L8	Force 8 (high)	
L6	Motor force on closure	L1	Force 1 (low)	Adjusts the motor force control system to adapt it to the weight of the pole during the closing manoeuvre and consequently the sensitivity of obstacle detection. <b>Note</b> – The force is acquired automatically during execution of the first two manoeuvres.
		L2	Force 2	
		L3	Force 3	
		L4	Force 4	
		L5	Force 5	
		L6	Force 6	
		L7	Force 7	
		L8	Force 8 (high)	
L7	Maintenance warning	L1	2500	When the FLASH output is programmed as a maintenance indicator: this sets the maximum number of manoeuvres to be performed, after which the signal is sent to notify of the need for automation maintenance.
		L2	5000	
		L3	10000	
		L4	15000	
		L5	20000	
		L6	30000	
		L7	40000	
		L8	50000	
L8	List of faults	L1	Manoeuvre 1 result (most recent)	The type of fault that has occurred in the last 8 manoeuvres can be established (see: paragraph 8.2 - malfunction event log and Table 14). A detailed log can be stored of all events on SBAR (and other devices connected on the network) by connecting the Oview programmer
		L2	Manoeuvre 2 result	
		L3	Manoeuvre 3 result	
		L4	Manoeuvre 4 result	
		L5	Manoeuvre 5 result	
		L6	Manoeuvre 6 result	
		L7	Manoeuvre 7 result	
		L8	Manoeuvre 8 result	







**Note** – Grey colour represents the factory setting.

**WARNINGS:**

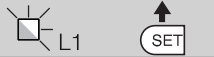
- Do not set an excessively high value for the "motor force" as this may impair operation of the safety system or damage the pole;
- If the "Motor force control" is used in support of the system for impact force reduction, after each adjustment the force measurement procedure must be performed, as envisaged by standard EN 12445.
- Wear and atmospheric conditions influence movement of the pole; motor force settings should be checked periodically.

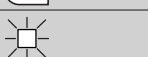

TABLE 8 - Programming procedure (second level functions)

01. Press and hold down the "Set" key for approx. 3 seconds;	
02. Release the key when LED L1 starts flashing;	
03. Press keys "▲" or "▼" to move from the flashing led to the led associated with the function to be modified;	
04. Press and hold the "Set" key through to completion of point 06;	
05. Wait approx. 3 seconds, until the LED representing the current level of the parameter to be modified illuminates;	
06. Press keys ▲ or ▼ to move the LED representing the value of the parameter;	
07. Release the "Set" key;	
08. Wait 10 seconds (maximum time) to exit the programming mode.	

**Note** – During this procedure, points 03 to 07 need to be repeated when programming other parameters during the phase itself.

## 7 WHAT TO DO IF... (troubleshooting guide)

Possible causes of malfunctions are listed below, which may occur during the installation phase, or in the case of faults, possible remedies:

- **The radio transmitter does not control the barrier and the transmitter led does not illuminate:** Check that the transmitter batteries are not discharged and replace if necessary.
- The radio transmitter does not control the barrier but the transmitter led illuminates: check that the transmitter is correctly memorised on the radio receiver. Ensure correct emission of the radio signal of the transmitter with the following empirical test: Press a key and place the led against the aerial of a standard radio switched on and tuned to FM at the frequency of 108.5Mhz or as close to this value as possible; a slight noise with a scratching pulse noise should be heard.
- **No manoeuvre is performed when a command is sent, and the OK led does not flash:** check that the barrier is powered via the mains at 230 V. Also check that the fuses F1 and F2 are not blown; in this case try to locate the cause of the fault and then replace with a version with the same specifications; see fig. 42.
- **No manoeuvre is performed when a command is sent, and the flashing light remains off:** check that the command is effectively received; if the sent command reaches the SS input, the OK led emits a double flash to indicate that the command is received.
- **The manoeuvre does not start and the courtesy light flashes a few times:** count the number of flashes and check with reference to the data in Table 9 in Chapter 8.
- The manoeuvre is performed, but shortly afterwards the pole blocks and performs a brief inversion: the selected force value may be too low to enable movement of the pole. Check correct balancing of the pole; if necessary set a higher force value.

## 8 FURTHER DETAILS

### 8.1 - Total deletion of control unit memory

It is possible to delete all memorised data on the control unit and reset it to the original factory settings:

01. Press and hold down "▲" and "▼" keys at the same time;
02. Release the keys when all Led illuminate (after approx.3 seconds);
03. When leds L1 and L2 start flashing, this means that the procedure is terminated.

**Important** – This procedure does not delete the parameter regarding the direction of motor rotation and the number of manoeuvres performed.

### 8.2 - Other functions

#### • "Always open" function

This function is a special feature of the control unit; it is associated with the "Step Step" input and enables an "always open" command when the Step Step command remains active for more than 3 seconds. This function is valid for any setting of the Step Step input (see "SS Function" in Table 7).

For example, it can be used to connect a clock for programming permanent opening of the barrier during a specific time band.

#### • "Move anyway" function

If one or more safety devices malfunctions or is out of service, this function enables control of the barrier in "hold-to-run" mode (for details, see chapter "operation manual").

#### • "Maintenance notification" function

This function enables notification of when an automation maintenance check is necessary. The "Maintenance notification" parameter can be set with a value on 8 different levels (see Table 7).

The levels refer to the number of manoeuvres performed. The maintenance notification is signalled via the Flash flashing light or by the maintenance indicator according to the type of setting. The signals emitted by the Flash flashing light and the maintenance indicator are shown in Table 9.

#### • Check of number of manoeuvres performed

The function "Maintenance notification" enables the user to check the number of manoeuvres performed as a percentage of the maximum set limit. Proceed as shown in Table 10.

#### • Manoeuvre counter reset

The manoeuvres can be reset at the end of the automation maintenance phase. To proceed, see Table 11.

TABLE 9

Number of manoeuvres	Flash flashing light	Maintenance indicator
Below 80% of the limit	Normal (0.5 sec. lit - 0.5 sec. off)	Light on for 2 seconds at the start of the opening manoeuvre.
Between 81% and 100% of the limit	Light on for 2 seconds at the start of the manoeuvre.	Flashing for entire duration of manoeuvre then continuing as normal
Over 100% of the limit	At the start and end of the manoeuvre, remains lit for 2 sec., then continues as normal.	Always flashes

TABLE 10















01. Press and hold down the "Set" key for approx. 3 seconds;	
02. Release the key when LED L1 starts flashing.	
03. Press keys "▲" or "▼" to move from the flashing led to led L7;	
04. Press and hold the "Set" key through to completion of point 07;	
05. Wait approx. 3 seconds, until the LED representing the current level of the "Maintenance Notification" illuminates;	
06. Press and immediately release the "▲" or "▼" keys;	
07. The led corresponding to the selected level shows a series of flashes, to indicate that the manoeuvre counter has been reset. The number of flashes indicates the percentage of the set limit of manoeuvres performed (as multiple of 10%). Example: when the maintenance notification is set on L7 (40000), 10% corresponds to 1000 manoeuvres; if the indicator led flashes 4 times, this means that 40% of the manoeuvres have been completed (between 4000 and 4999 manoeuvres). If at least 10% of the manoeuvres has not yet been reached, no flashes are emitted;	 <ul style="list-style-type: none"> <li>x 1 = 10-19%</li> <li>x 2 = 20-29%</li> <li>x 3 = 30-39%</li> <li>x 4 = 40-49%</li> <li>x 5 = 50-59%</li> <li>x 6 = 60-69%</li> <li>x 7 = 70-79%</li> <li>x 8 = 80-89%</li> <li>x 9 = 90-99%</li> <li>x 10 = &gt; 100%</li> </ul>
08. Release the "Set" key.	

TABLE 11

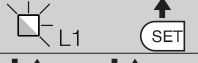



01. Press and hold down the "Set" key for approx. 3 seconds;	
02. Release the key when LED L1 starts flashing.	
03. Press keys "▲" or "▼" to move from the flashing LED to L7 LED ("input LED" for the "Maintenance Notification" parameter);	
04. Press and hold the "Set" key through to completion of point 07;	
05. Wait approx. 3 seconds, until the LED representing the current level of the "Maintenance Notification" illuminates;	
06. Press and hold keys "▲" and "▼" for at least 5 seconds, then release. During this phase the led corresponding to the selected level shows a series of quick flashes to indicate that the manoeuvre counter has been reset;	
07. Release the "Set" key.	

#### • Fault log

This function enables display of any faults occurring during the last 8 manoeuvres, such as an interruption to a manoeuvre caused by activation of a photo-

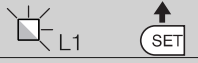
cell or a sensitive edge. To check the list of faults, proceed as described in Table 12.

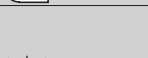
TABLE 12

01. Press and hold down the "Set" key for approx. 3 seconds;	
02. Release the key when LED L1 starts flashing.	
03. Press keys "▲" or "▼" to move from the flashing LED to L8 LED ("input LED" for the "Fault log" parameter);	
04. Press and hold the "Set" key through to completion of point 06;	
05. Wait approx. 3 seconds until the LEDs representing the levels corresponding to the manoeuvres with faults illuminate. Led L1 indicates the result of the most recent manoeuvre, and led L8 indicates the result of the eighth manoeuvre; if a led is lit, this means that one or more faults have occurred during the manoeuvre; if off this means that the manoeuvre has been completed correctly.	
06. Press keys "▲" and "▼" to select the required manoeuvre: the corresponding LED performs a number of flashes equal to those normally performed by the flashing light after a fault occurs (see Table 15);	
07. Release the "Set" key.	

### 8.3 - Adding or removing devices

New devices can be added at any time, connected to the BlueBus and Stop input or those present can be deleted as required. To do this, proceed as follows:

**01.** Press and hold down "▲" and "Set" keys at the same time;

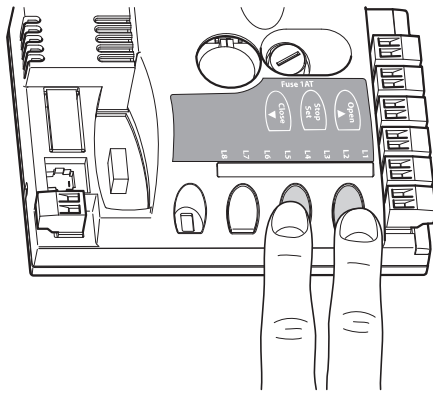

- 02.** Release the buttons when L1 and L2 LED's start flashing very quickly (after approx. 3 s);
- 03.** Wait a few seconds for the control unit to finish connected device self-learning;
- 04.** At the end of this phase, the STOP led must remain lit, while leds L1 and L2 turn off (where relevant leds L3 and L4 start flashing).

After performing this procedure, the automation testing procedure must be performed as described in chapter 5.1.

#### 8.3.1 - Bluebus Inlet

This Bluebus system allows device connections to be made using just 2 conductors for both the electricity supply and the communication signals. All devices are connected in parallel on the same 2 Bluebus wires, without the need to observe polarity; Each device is individually recognized because a unique address is assigned to it during installation. Bluebus can be used to connect the following: photocells, safety devices, control devices such as keyboards and readers for transponder cards, indicator lamps, etc. The control unit recognises each one of the devices connected during the self-learning phase and is able to detect all possible faults in maximum safety. For this reason each time a device is connected to or removed from Bluebus the self-learning phase must be repeated, as described in paragraph 4.4.

#### 8.3.2 - Photocells

The Bluebus system enables the control unit to recognise the photocells, control routing of the relative jumpers (see Table 13) and enables assignment of the correct value for the obstacle detection function. The routing operation is performed both on TX and RX, positioning the jumpers in the same way with a check that there are no pairs of photocells with the same address. The photocells can be installed as shown in fig. A. Important – After installing or removing the photocells, the device learning phase must be performed, as described in paragraph 4.4.

TABLE 13 - PHOTOCELL ADDRESSES

Photocell	Jumpers
<b>PHOTO</b> Photocell h = 50 activated on closure	
<b>PHOTO II</b> Photocell h = 100 activated on closure	
<b>PHOTO 1</b> Photocell h = 50 activated on closure	
<b>PHOTO 1 II (*)</b> Photocell h = 100 activated on closure	
<b>PHOTO 2</b> Photocell activated on opening (inverts on closing)	
<b>PHOTO 2 II</b> Photocell activated on opening (inverts on closing)	
<b>PHOTO 3</b> Single photocell activated on opening and closing	

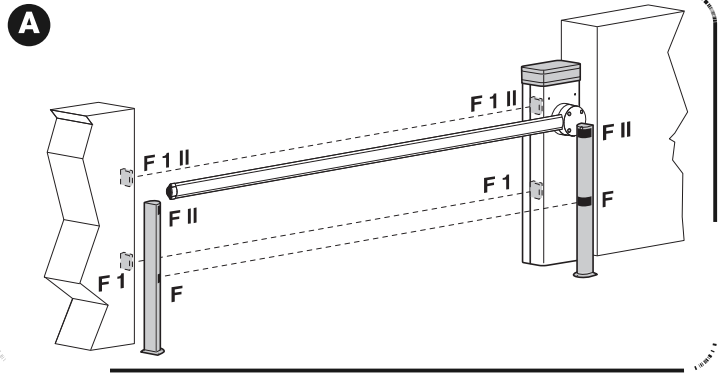

It is possible to install the TX or RX photocell inside the caisson of the barrier, in the space provided (fig. 43).

To install the photocell, proceed as follows:

- 01.** Extract the board of the photocell from its box by prising it out with a slotted tip screwdriver (fig. 43-a). **IMPORTANT!** - Do not damage the electric components inside;
- 02.** Open the box prepared for the photocells, present in the accessory box (fig. 47-b);
- 03.** Block the board on the bottom of the box (fig. 43-c);
- 04.** Pierce the rubber arranged for the passage of the electric cable (fig. 43-d);
- 05.** Route the electric cable and connect it to the terminal of the photocell (fig. 43-e);
- 06.** Close the bottom of the box with the cover, taking care to block the rubber in its seat (fig. 43-f);
- 07.** Hook the box on the lens on the side of the caisson by making it slide from top to bottom (fig. 43-g).

#### 8.3.3 - MOTB digital selector and proximity reader for MOMB transponder cards

The Bluebus system enables connection of up to 4 MOTB digital selectors or 4 MOMB transponder badge readers. MOTB enables control of the automation, by entering one of the memorised numerical codes on the keypad. MOMB enables control of the automation by simply placing the memorised transponder badge close to the automation. These devices have an individual code, which is recognised and memorised by the control unit during the phase for learning all connected devices (see paragraph 4.4).

This prevents an fraudulent attempts to replace a device or use of the automation by unauthorised persons. For further information, refer to the instruction manual for MOTB and MOMB.

#### 8.3.4 - STOP Input

The Stop input causes the manoeuvre to stop immediately followed by a short reverse run. Devices with normally open NO or normally closed NC contact outputs, optical devices (Opto Sensors), or devices with 8.2 kΩ constant resistance output such as sensitive edges can be connected to this input. The control unit, during the learning phase, recognises the type of device connected and activates a STOP command when any variation in the learnt status occurs. When set accordingly, more than one device can be connected to the STOP input, also different from one another;

- Several NO devices can be connected in parallel, with no limit to the number;
- Several NO devices can be connected in series, with no limit to the number;
- Two devices with an 8.2KΩ constant resistance output can be connected in parallel; multiple devices must be connected "in cascade" with a single 8.2KΩ termination resistance;
- An NO and NC type combination is also possible, placing the 2 contacts in parallel. In this case, a 8.2 KΩ resistance must be placed in series with the NC contact; this also enables the combination of 3 devices: NO, NC and 8.2 KΩ.

**Caution** – If the STOP input is used to connect devices with safety functions, only the devices with a constant resistance of 8,2 KΩ or OPTO SENSOR optical devices guarantee adequate safety levels against faults.

For connection of an optical device type OPTO SENSOR make the connections as shown in fig. 44. The maximum current provided on the 12 Vdc line is 40 mA.

### 8.4 - Diagnostics

Some devices are able to emit signals that serve to recognise their state of operation or possible faults.

#### 8.4.1 - Signals of control unit

The leds of the terminals and the keys on the control unit (fig. 45) emit special signals both to indicate normal operation and possible faults. Tables 14 and 15 describe the cause and solution for each type of signal.

TABLE 14 - Terminal LEDs on control unit

Bluebus LED	Cause	Solution
Off	Fault	Check for presence of the power supply; check that the fuses are not blown; in this case, identify the cause of the fault and then replace with versions with the same specifications.
On	Serious fault	This indicates a serious fault; try switching off the control unit for a few seconds; if the condition persists there is a fault and the electronic board needs to be replaced.
1 flash per second	All OK	Normal operation of control unit
2 quick flashes	Input status variation	A variation to the status of the inputs SS, STOP, OPEN, CLOSE, activation of the photocells, or when the radio transmitter is used, is normal.
Series of flashes separated by a pause	Various	This is the same signal of 1 second as on the flashing light (See table 15)
Led STOP	Cause	Solution
Off	STOP input activation	Check the device connected to the STOP input
On	All OK	Ingresso STOP attivo
S.S. LED	Cause	Solution
Off	All OK	S.S. Input not active
On	S.S. input activation	Normal if the device connected to the S.S. input is active
OPEN LED	Cause	Solution
Off	All OK	OPEN input not active
On	OPEN input activation	Normal if the device connected to the OPEN input is active
CLOSE LED	Cause	Solution
Off	All OK	CLOSE input not active
On	CLOSE input activation	Normal if the device connected to the CLOSE input is active

TABLE 15 - Button LEDs on control unit

Led 1	Description
Off	During normal operation, indicates "Automatic closure" not active.
On	During normal operation, indicates "Automatic closure" active.
Flashes	<ul style="list-style-type: none"> <li>Programming of functions in progress.</li> <li>If this flashes together with L2 this indicates that the device learning phase must be performed (see paragraph 4.4).</li> </ul>
Quick flash	After control unit start-up, it indicates a memory error regarding the <u>devices connected</u> . At the same time, the "Bluebus" led emits a diagnostic signal: 5 flashes - pause of 1 second - 5 flashes. In this case the learning phase for connected devices must be performed (see paragraph 4.4).
Led 2	Description
Off	During normal operation, indicates "Re-close after photo" not active.
On	During normal operation, indicates "Re-close after photo" active.
Flashes	<ul style="list-style-type: none"> <li>Programming of functions in progress.</li> <li>If this flashes together with L1 this indicates that the device learning phase must be performed (see paragraph 4.4).</li> </ul>
Quick flash	After control unit start-up, it indicates a memory error regarding the <u>positions</u> . At the same time, the "Bluebus" led emits a diagnostic signal: 5 flashes - pause of 1 second - 5 flashes. In this case the learning phase for the Opening and Closing positions must be performed (see paragraph 4.5).
Led 3	Description
Off	During normal operation, indicates "Re-close after photo" not active.
On	During normal operation, indicates "Re-close after photo" active.
Flashes	<ul style="list-style-type: none"> <li>Programming of functions in progress</li> <li>If this flashes together with L1 this indicates that the device learning phase must be performed (see paragraph 4.4).</li> </ul>
Quick flash	After control unit start-up, it indicates a memory error regarding the <u>parameters and configurations</u> . At the same time, the "Bluebus" led emits a diagnostic signal: 5 flashes - pause of 1 second - 5 flashes. In this case the memory must be deleted (see paragraph 8.1), and also the learnt connected devices (see paragraph 4.4) and learnt Opening and Closing positions (see paragraph 4.5).
Led 4	Description
Off	During normal operation, indicates "Stand-BY" not active.
On	During normal operation, indicates "Stand-BY" active.
Flashes	<ul style="list-style-type: none"> <li>Programming of functions in progress</li> <li>If this flashes together with L3 this indicates that the pole opening and closing learning phase must be performed (see paragraph 4.5).</li> </ul>
Led 5	Description
Off	During normal operation, indicates "Short deceleration" active.
On	During normal operation, indicates "Long deceleration" active.
Flashes	Programming of functions in progress.
Led 6	Description
Off	During normal operation, indicates "Pre-flash" not active.
On	During normal operation, indicates "Pre-flash" active.
Flashes	Programming of functions in progress.
Led 7	Description
Off	During normal operation, indicates "Current sensitivity control" not active.
On	During normal operation, indicates "Current sensitivity control" active.
Flashes	Programming of functions in progress.

Led 8	Description
Off	During normal operation it indicates that Pole closing is set to the left.
On	During normal operation it indicates that Pole closing is set to the right
Flashes	Programming of functions in progress.

### 8.4.2 - Flashing light signals

If a flashing light is connected to the FLASH output on the control unit (or the edge light if the LED flashing light XBA7 is connected, optional accessory), this emits flashes at intervals of 1 second during execution of a manoeuvre. If faults

occur, the flashing light will emit shorter flashes; these are repeated twice, separated by a 1 second pause. The same signals are also emitted by the courtesy light and the "Bluebus" led. **Table 16** shows the cause and solution for each type of signal.

**TABLE 16**

Signal	Cause	Solution
1 flash second pause 1 flash	Bluebus system error	At the start of the manoeuvre, the devices connected to Bluebus do not correspond to those recognized during the self-learning phase. One or more devices may be faulty; check and, if necessary, replace them. In case of modifications repeat the device self-learning process (see paragraph 4.5).
2 flashes second pause 2 flashes	Photocell activated	At the start of the manoeuvre, one or more photocells do not enable it; check to see if there are any obstacles.
3 flashes second pause 3 flashes	Activation of Motor Force limiter	During the movement, the pole has experienced excessive friction; identify the cause.
4 flashes second pause 4 flashes	STOP input activation	At the start of the manoeuvre or during the movement, the STOP input was activated; identify the cause.
5 flashes second pause 5 flashes	Error on internal parameters in control unit	Wait at least 30 seconds, then try giving a command. If the condition persists, there may be a serious malfunction and the electronic board must be replaced.
6 flashes second pause 6 flashes	Maximum limit of manoeuvres per hour exceeded	Wait a few minutes until the manoeuvre limiting device falls to below the maximum limit.
7 flashes second pause 7 flashes	Error in internal electric circuits	Disconnect all power circuits for a few seconds and then retry a command; if the condition persists this may indicate a serious fault with the board or motor wiring. Check and make replacements as necessary.
8 flashes second pause 8 flashes	–	Reserved for Nice Technical Assistance
9 flashes second pause 9 flashes	Block automation	Send the command "Release automation" or control the manoeuvre with "High Priority Step Step".

## PRODUCT DISPOSAL

This product is an integral part of the automation system it controls and must be disposed of along with it.

As in the case of installation, likewise at the end of product lifetime the disassembly and scrapping operations must be performed by qualified personnel.

This product is made of various types of material, some of which can be recycled while others must be scrapped. Seek information on the recycling and disposal methods envisaged by the local regulations in your area for this product category.

**Caution!** – Some parts of the product may contain polluting or hazardous substances which, if released to the environment, may cause serious damage to the environment or to human health.

As indicated by the symbol alongside, disposal of this product with domestic waste is strictly prohibited. Separate the waste into categories for disposal, according to the methods established by current legislation in your area, or return the product to the retailer when purchasing a new version.



**Caution!** – Local legislation may impose heavy fines in the event of illegal disposal of this product.

## TECHNICAL CHARACTERISTICS OF THE PRODUCT

**WARNINGS:** • All technical specifications stated in this section refer to an ambient temperature of 20°C (± 5°C). • Nice S.p.a. reserves the right to apply modifications to products at any time when deemed necessary, maintaining the same intended use and functionality.

Product Type	SBAR is an electromechanical road barrier for residential use. Controls opening and closing of an access point with a maximum width of 4 m. Complete with electronic control unit
Maximum torque on start-up	100 Nm
Nominal torque	25 Nm
Maximum operating cycle frequency at nominal torque *	100 (80 with XBA4 accessory) cycles / hour
Maximum continuous operating time at nominal torque **	10 (8 with XBA4 accessory) minutes
Opening time	≥ 4 s (>5s with XBA4 accessory)
Durability	between 80,000 and 500,000 manoeuvre cycles according to the conditions stated in Table 2
Peak power supply	230 Vac (50/60Hz)
Peak power absorption on start-up	300W
Maximum power at nominal torque	200 W
Insulation class	I
Emergency power supply	Yes (with PS124 accessory)
Courtesy light	With XBA7 LED flashing accessory
Flashing light output	For 1 flashing light LUCYB, MLB or MLBT (12 V - 21 W lamp)
BLUEBUS output	1 output with maximum load of 12 Bluebus units
STOP Input	For normally closed, normally open or 8.2 kΩ; constant resistance contacts in self-learning mode (a change from the memorised state prompts the "STOP" command)
S.S. input	For normally open contacts (closure of the contact prompts the Step by Step command)
OPEN Input	For normally open contacts (closure of the contact prompts the OPEN command)
CLOSE Input	For normally open contacts (closure of the contact prompts the CLOSE command)
Radio AERIAL input	52 Ω for RG58 or similar type cable
Radio connector	SM connector for receiver types SMXI, SMXIS or OXI, OXIT and OXIFM
Programmable functions	8 ON-OFF type functions and 8 adjustable functions (see tables 6 and 7)
Functions in self-learning mode	Self-learning of devices connected to the BlueBus output. Self-learning of "STOP" type devices (contacts NO, NC or 8,2KΩ). Learning of pole opening and closing positions and calculation of the points of deceleration and partial opening
Operating temperature	from -20° C to +50° C
Use in particularly acid, saline or potentially explosive atmospheres	No
Protection rating	IP 44
Dimensions	1146 x 330 h 179,5; <b>pole:</b> minimum 2 m - maximum 4 m
Weight	35 Kg

**Note:**

(\*) At 50°C the maximum operating frequency is 40 cycles/hour

(\*\*) At 50°C the maximum continuous operating time is 5 minutes.



## APPENDIX I

To be used only in the case of installations in conformity with chapter 1 and more specifically paragraph 1.3.1  
To be detached, compile box N°1 and deliver to automation owner together with the operation manual and maintenance schedule

## CE declaration of conformity

Declaration in accordance with Directives: 2004/108/EC (EMC); 2006/42/EC (MD) annex II, part A;  
89/106/CEE (CPD) procedure according to appendix III, ii, possibility 2 (System 3)

## Box N° 1

The installation of the product: SBAR Road Barrier matricola N° serial N° (see label): .....

Complete with pole: XBA4 and following accessories: .....

Was performed by:

Company: ..... Address: .....

Name and Surname of responsible installer: .....

The installer hereby declares to have strictly observed all provisions of the instruction manual enclosed with the product:

Data ..... Signature: .....

Place of product installation, at: ..... Address: .....

**Caution! – This declaration of conformity is not to be considered valid if all fields in this box are not duly compiled.**

**Note** - The content of this declaration corresponds to the declaration made in the official document filed in the offices of Nice S.p.a., and particularly the latest version thereof available prior to the printing of this manual. The text contained here has been adapted to meet editorial requirements. A copy of the original declaration may be requested from Nice S.p.a. (TV) I

Declaration number: 407/SBAR Revision: 0 Language: EN

Name of manufacturer: NICE s.p.a.  
Address: Via Pezza Alta 13, Rustignè Industrial Zone, 31046 Oderzo (TV) Italy  
Person authorized to provide technical documentation: Mr. Oscar Marchetto  
Product type: Electromechanical barrier lift  
Model: SBAR  
Accessories: XBA7, XBA4, XBA13, XBA19

The undersigned Luigi Paro, as Managing Director, hereby declares under his own responsibility that the product identified above complies with the provisions of the following directives:

- DIRECTIVE 2004/108/EC OF THE EUROPEAN PARLIAMENT AND COUNCIL of December 15 2004 concerning alignment of Member States' legislation regarding electromagnetic compatibility and abrogating directive 89/336/EEC, according to the following harmonized standards: EN 61000-6-2:2005, EN 61000-6-3:2007
- Directive 2006/42/EC OF THE EUROPEAN PARLIAMENT AND COUNCIL of May 17 2006 regarding machines and amending directive 95/16/EC (consolidated text)  
Should the machinery be put into service in a European country with an official language different from the one of this declaration, the importer must attach the translation of this document to the declaration,
- Directive 89/106/EEC of the European Council of 21 December 1988 regarding the approximation of legislation, regulations and administration of Member States concerning construction products, according to the following harmonised standards: EN 13241-1:2003

## Essential requirements for CE marking for Directive 89/106/EEC

Characteristics	Certifying Authority	Document
Release of hazardous substances	CERT(CPD no. 1600)	prot. no. 246-03/AC/lz
Resistance to wind load	CERT(CPD no. 1600)	1157/08
Safe opening for vertically moving doors	CERT(CPD no. 1600) 1159/08	
Mechanical strength and stability	- - -	167TCF08 SP S14
Manoeuvring forces for power-operated doors/gates	CERT(CPD n°1600)	1158/08

(\* ) CERT of Treviso Tecnologia in Lancenigo di Villorba (TV)

The product also complies with the following standards:  
EN 60335-1:2002 + A1:2004 + A11:2004 + A12:2006 + A2:2006 + A13:2008

The parts of the product which are subject to the following standards comply with them:  
EN 13241-1:2003, EN 12445:2002, EN 12453:2002, EN 12978:2003, EN 60335-2-103:2003

Oderzo, June 30 2011

Mr. Luigi Paro (Managing Director)



# Operation manual

## (to be given to the final user of SBAR)

Before using the automation for the first time, ask the installer to explain the origin of residual risks and devote a few minutes to reading this user instruction and warning manual given to you by the installer. Keep the manual for reference when in doubt and pass it on to new owners of the automation.

**CAUTION!** – Your automation is a machine that performs your commands faithfully; negligent or improper use may constitute a hazard:

- **Never activate automation controls if persons, animals or objects are present in the operating range.**
- **Never touch parts of the automation while the pole is moving!**
- **Transit is only permitted if the pole is completely open and stationary!**

### Warnings

**1 - Children:** An automation system guarantees a high level of safety, using its detection systems to prevent movement in the presence of persons or objects, and ensuring constantly foreseeable and safe activation. Nonetheless, it is advisable to ensure that children do not play in the vicinity of the automation. To prevent the risk of accidental activation, do not leave the remote controls within the reach of children. this is not a toy!

**2 -** This product is not designed to be used by persons (including children) whose physical, sensorial or mental capacities are reduced, or with lack of experience or skill, unless suitable instructions regarding use of the product have been provided by a person responsible for safety or under supervision of the latter.

**3 - Malfunctions:** if the automation is seen to perform abnormally, disconnect the electrical power supply from the system and manually release the gearmotor. Never attempt to perform repairs; contact your local installer for assistance. In the meantime the system can be used as a manual access point, after releasing the gearmotor as described below in this document. **In the event of breakage or a power failure, while waiting for the installer or the electrical power supply to return, if the buffer battery is not fitted, the automation can still be used.** Manually release the gearmotor (see step 9 - Gearmotor manual releasing and locking) and move the pole manually as required.

**4 - Safety devices disabled:** the barrier can be operated even when the safety device on the barrier do not work correctly.

- Activate the barrier command (with the transmitter or key-operated selector switch, etc.); if all is in working order, the pole opens or closes normally; otherwise the flashing light emits a number of flashes and the manoeuvre is not started (the number of flashes depends on the reason for which the manoeuvre does not start).
- In this case, the user must press and hold the command within three seconds.
- After approx. 2 seconds the barrier will start to operate in “hold-to-run” mode, i.e. the pole will continue to move while the command is activated; **THE POLE STOPS AS SOON AS THE COMMAND IS RELEASED.**

**If the safety devices are out of service, the automation must be repaired as soon as possible.**

**5 -** Even if you possess the skills, never modify the system or programming and setting parameters of the automation: this is the responsibility of the installer.

**6 -** Testing, periodic maintenance and any repairs must be documented by the person performing the operations and the relevant documents must be kept by the system owner. The only operations that can be performed by the user periodically are to clean the photocell lenses and the automation. To prevent anyone from activating the barrier release the automation system before proceeding with the operations (as described below). Use a slightly damp cloth to clean.

**7 - Disposal:** At the end of the automation’s lifetime, ensure that it is disposed by qualified personnel and that the materials are recycled or scrapped according to current local standards.

**9 - Gearmotor manual release and locking:** The gearmotor is equipped with a mechanical system that enables manual opening and closing of the pole. These operations are required in the event of a power failure or malfunctions.

### IMPORTANT!

- **The gearmotor release and locking operations must be performed only when the pole is horizontal and stationary.**
- **The gearmotor can be released manually on both sides of the barrier.**

- 01.** Unscrew the key cover (Fig. A - 1);
- 02.** Insert the key supplied and turn through 180° (Fig. A - 2);
- 03.** Move the pole as required (Fig. A - 3);
- 04.** To lock the gearmotor, rotate the key through a further 180°.

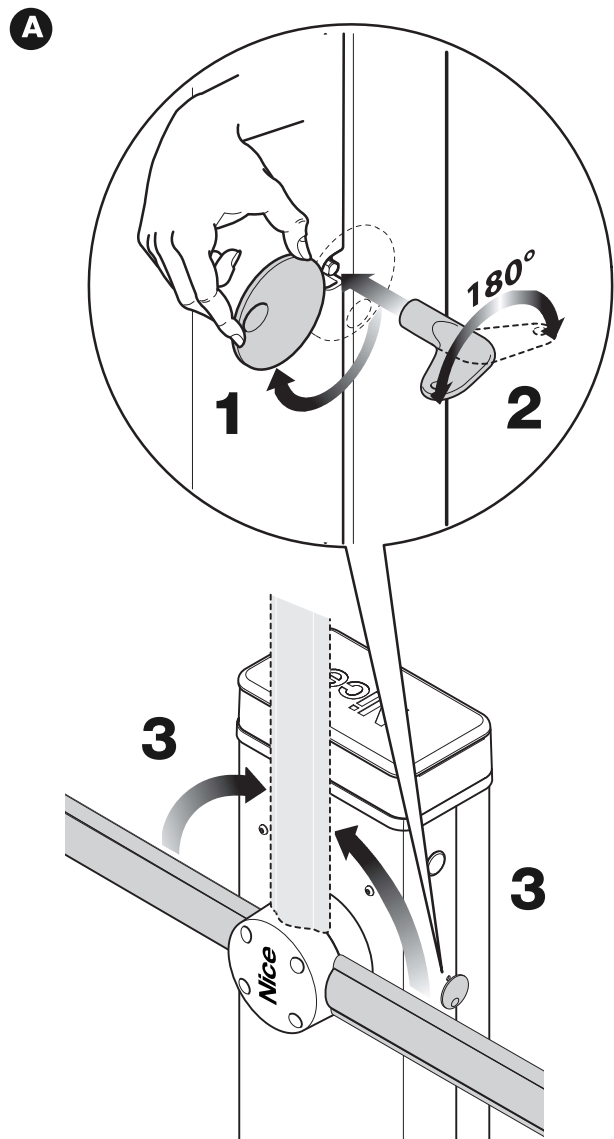

# Maintenance Schedule

(to be given to the final user of SBAR)

## MAINTENANCE REGISTER

**Important** – This register must be given to the automation owner after compilation of all required parts.

This register must list all maintenance operations, repairs and modifications performed. The Register must be updated on each operation and stored in a safe place for future inspections by authorised organisations.

This Maintenance Register refers to the following automation:

mod. SBAR. - Serial n° ..... - Date of installation ..... - at .....

The following enclosed documents are part of the Register:

- 1) - Maintenance schedule
- 2) - .....
- 3) - .....
- 4) - .....
- 5) - .....
- 6) - .....

According to the enclosed document “Maintenance Schedule”, maintenance operations must be performed at the following intervals: **every 6 months or each 10% of envisaged durability of manoeuvre cycles**, depending on which event occurs first.

## MAINTENANCE SCHEDULE

**Caution!** - System maintenance must be performed by technical and qualified personnel, in strict observance of safety standards as envisaged by current legislation and the safety precautions stated in Chapter 1 - “General safety warnings and precautions”, at the start of this manual.

In general, SBAR does not require special maintenance. However, regular checks over time will guarantee system efficiency and ensure correct operation of the safety systems installed.

If SBAR is equipped with other devices not mentioned in this manual, follow the instructions in the relative maintenance schedules.

Considering normal domestic use of the automation, periodic checks of the system are recommended Every 6 months or, more specifically, the period of maintenance can be calculated on the basis of these factors:

- If SBAR is set for use at high speeds, with high force levels or with the pole weight increased by the use of accessories, more frequent checks are required. In general; to establish the number of cycles between each maintenance operation, estimate the durability as specified in table 4 and plan intervention at least every 10% of the resulting manoeuvres; e.g. if total durability is 500,000 (\*); maintenance should be performed every 50,000 cycles.

(\* **Special warning regarding spring replacement:** the balancing system is based on the use of a spring. The lifetime of this spring is on average greater than 500,000 cycles, but for an adequate safety margin, the spring should be replaced before this limit.

Note also that in the event of spring breakage, SBAR still remains compliant with the requirement in 4.3.4 of the standard EN 12604: 2000.

- The pole balancing system must be checked at least twice a year, preferably when the season changes.

At the envisaged interval, the following checks and replacements must be made for maintenance.

- 1 Ensure that all specifications in this manual have been observed, with special reference to the chapter “1 Safety Instructions”.
- 2 Check correct balancing of the pole, see paragraph 3.8.
- 3 Check correct operation of the manual release, see paragraph 3.6.
- 4 Using the transmitter or key-operated selector switch, perform tests of opening, closing and stopping the barrier, and ensure that pole movement corresponds to specifications. Test several times to check for pole movement and any defects in assembly or adjustment and any possible points of friction.
- 5 Check operation of all system safety devices one at a time (photocells, sensitive edges, etc.). Each time a device is activated the “Bluebus” LED on the control unit must flash rapidly twice to confirm acknowledgement of the event.
- 6 Check correct operation of the photocells as follows: depending on whether one or two pairs of photocells have been installed, one or two parallelepipeds in rigid material are required (e.g. wooden panels) with the measurements 70 x 30 x 20 cm. Each parallelepiped must have three sides, one for each size, in reflective material (e.g. mirror

or white gloss paint) and three sides in opaque material (e.g. black matt paint). To test the photocells positioned at 50 cm from the ground, the parallelepiped must be placed on the ground or raised at 50 cm in the case of photocells placed at 1 m from the ground.

When testing one pair of photocells, the test specimen must be positioned exactly at the centre of the pole with the 20 cm sides facing the photocells and moved along the entire length of the pole (**fig. 46**).

When testing two pairs of photocells, the test must first be performed individually for each pair of photocells, using one test specimen, and then repeated using two test specimens.

Each test specimen must be positioned laterally with respect to the centre of the pole, at a distance of 15 cm sides and then moved along the entire length of the pole (**fig. 47**).

During these tests, the test specimen must be read by the photocells in any position.

- 7 To ensure there is no interference with other devices, pass a cylinder (diameter 5 cm, length 30 cm) through the optic axis joining the pair of photocells (**fig. 48**): pass the cylinder first close to the TX photocell, then close to the RX and lastly at the centre between the two. Ensure that in all cases the device engages, changing from the active status to alarm status and vice versa, and that the envisaged action is generated in the control unit (for example movement inversion in the *Closing* manoeuvre).
- 8 **Check protection against the risk of lifting:** on automations with vertical movement, it must be ensured that there is no risk of lifting. This test can be performed as follows: hang a weight of 20 kg midway along the pole (for example, a sack of gravel), activate an Opening manoeuvre and ensure that during operation the pole does not exceed the height of 50 cm from the closing position. If the pole exceeds this height, reduce the motor force (see chapter 6 - Table 7).
- 9 If hazardous situations generated by the moving poles are protected by means of impact force limitation, measure the force as specified in the standard EN 12445. If motor force control is used as auxiliary function with the system for reduction of impact force, test and identify the setting that obtains the best results.
- 10 **Check efficiency of the release system:** place the pole in the Closing position and manually release the gearmotor (see paragraph 3.6) ensuring that there is no difficulty with this procedure. Ensure that the manual force required to move the pole on opening is no greater than 200 N (approx. 20 Kg); the force is measured perpendicular to the pole and at 1 m from the rotation axis. Lastly, ensure that the key required for manual release is available in the vicinity of the automation.
- 11 **Power supply disconnection system check:** by using the power disconnect device, and disconnecting any buffer batteries, ensure that all leds on the control unit are off and that the rod remains stationary when any commands are sent. Check efficiency of the locking device to prevent inadvertent and/or unauthorised reconnection.



EN

Date	Description of operation <small>(describe checks, adjustments, repairs, modifications etc.)</small>	Signature of technician	Signature of owner
	<input type="checkbox"/> That all phases as envisaged in the maintenance schedule have been performed.		



1

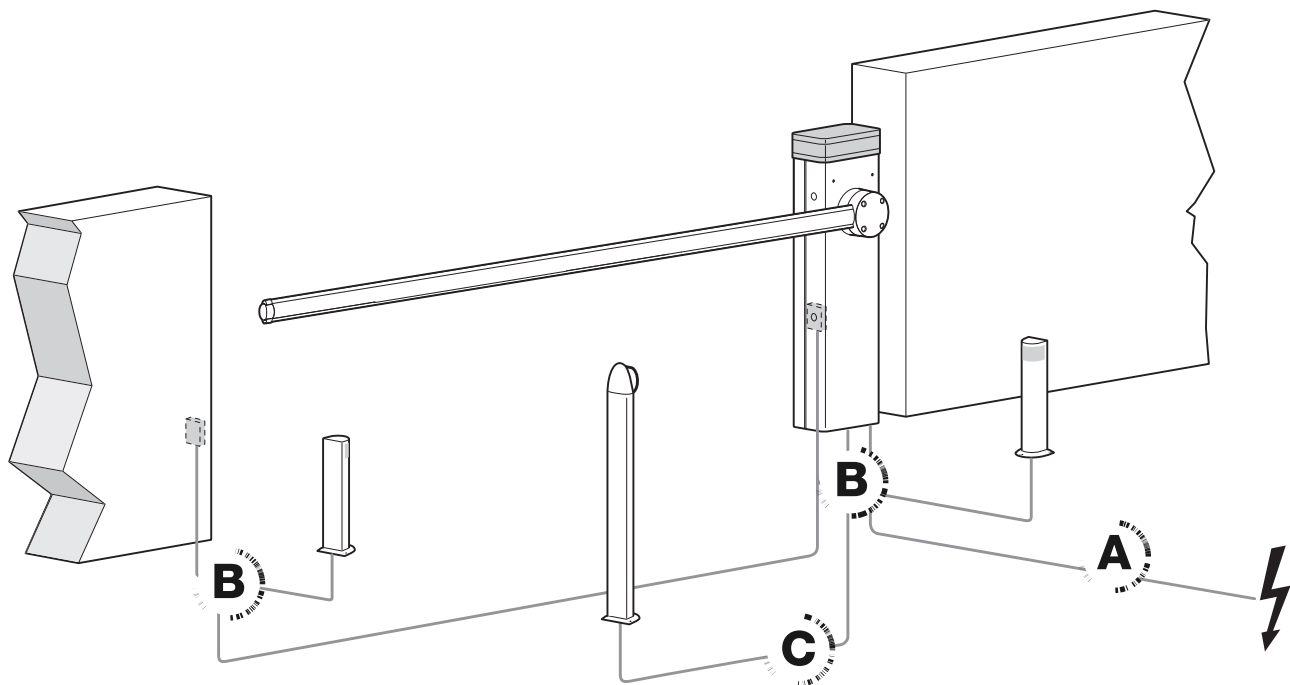

2

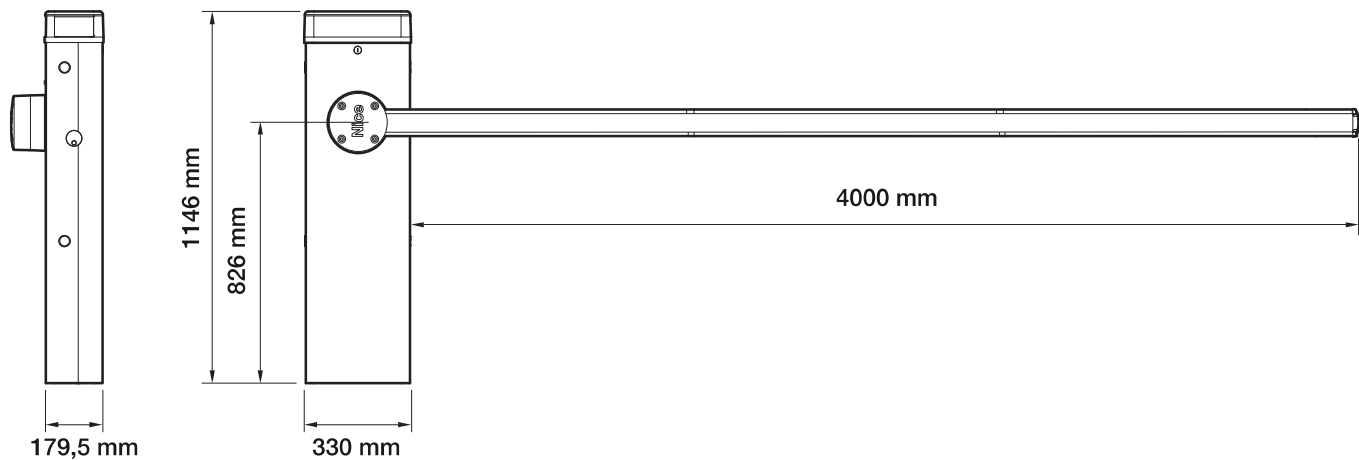

3

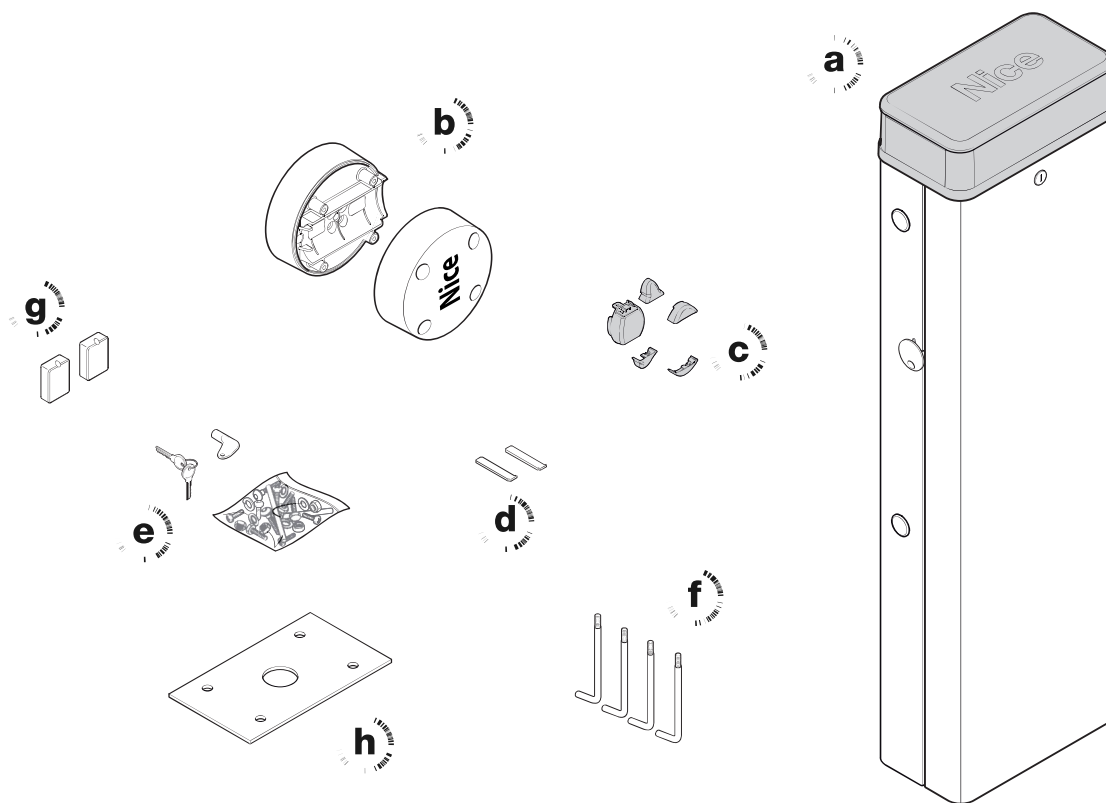

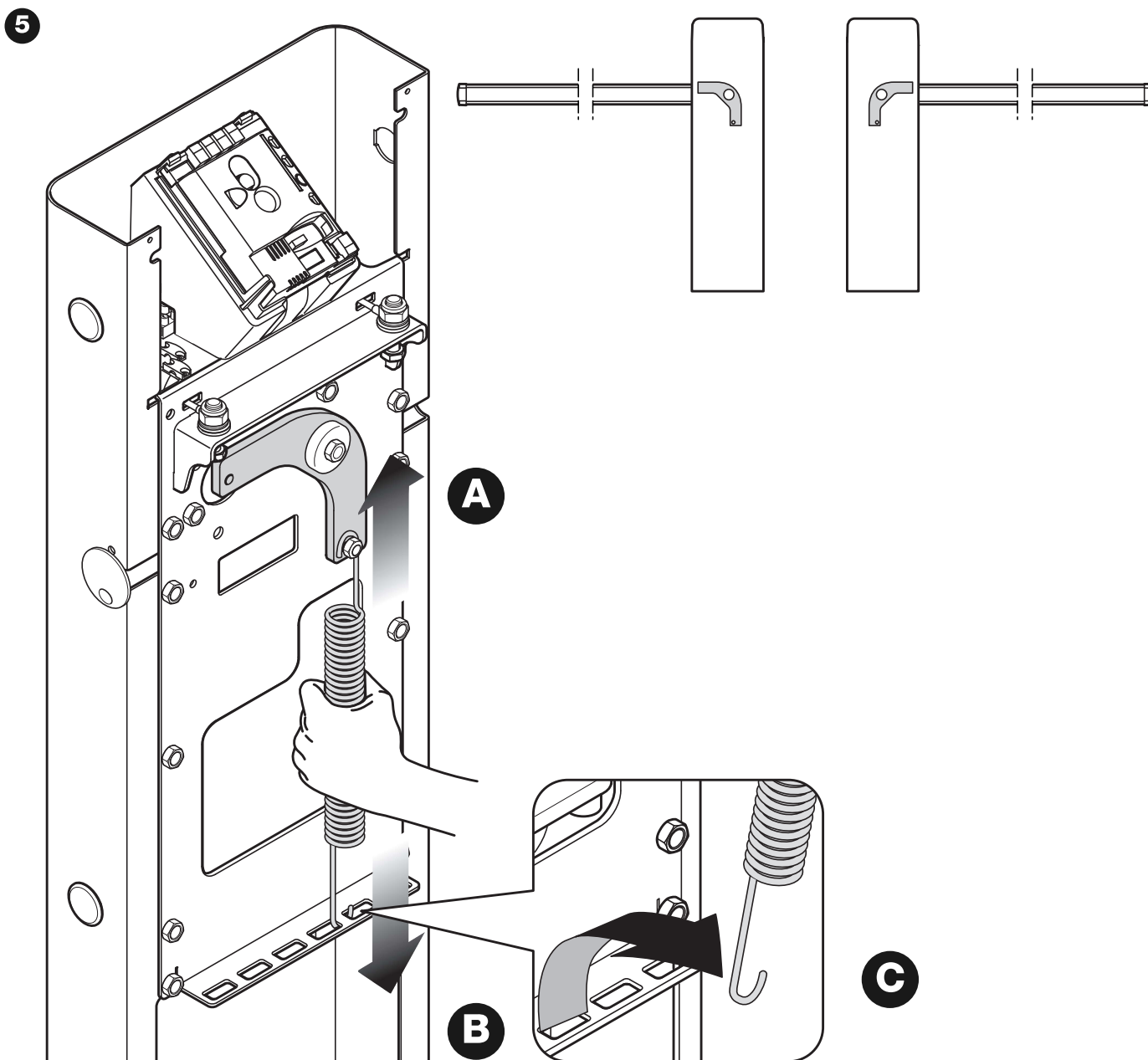
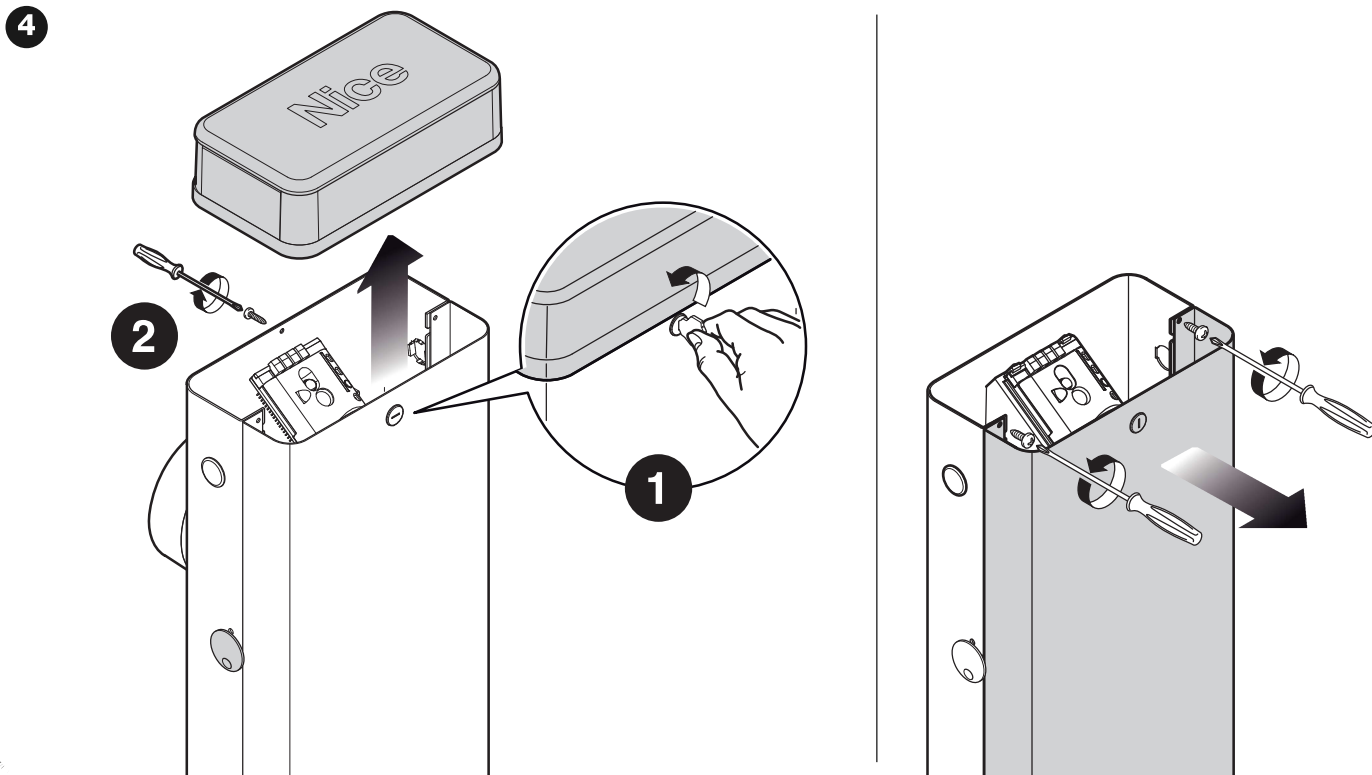



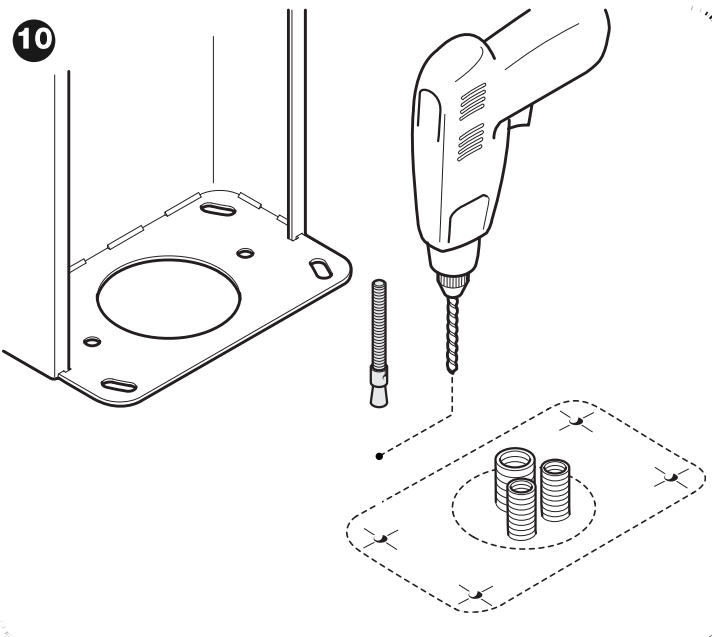
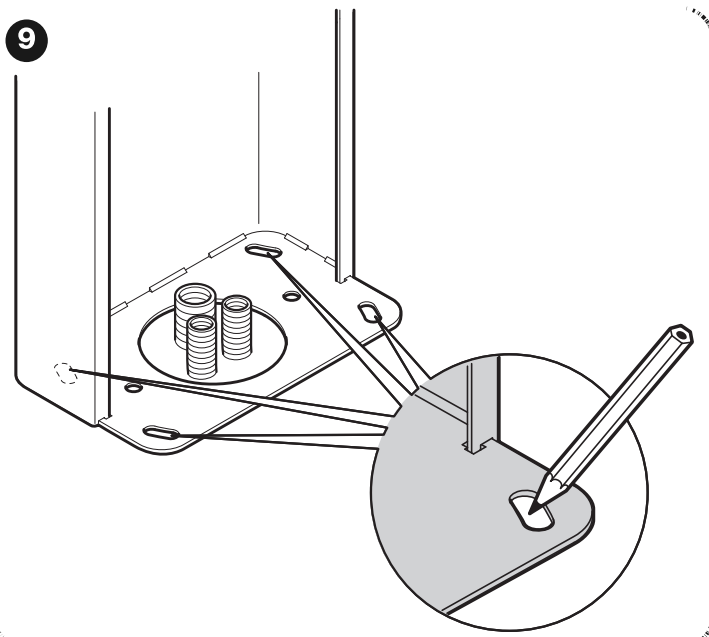
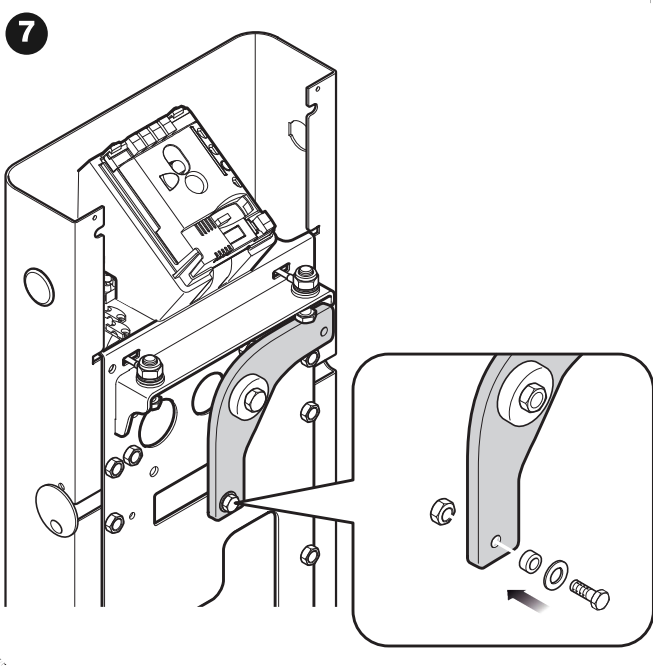
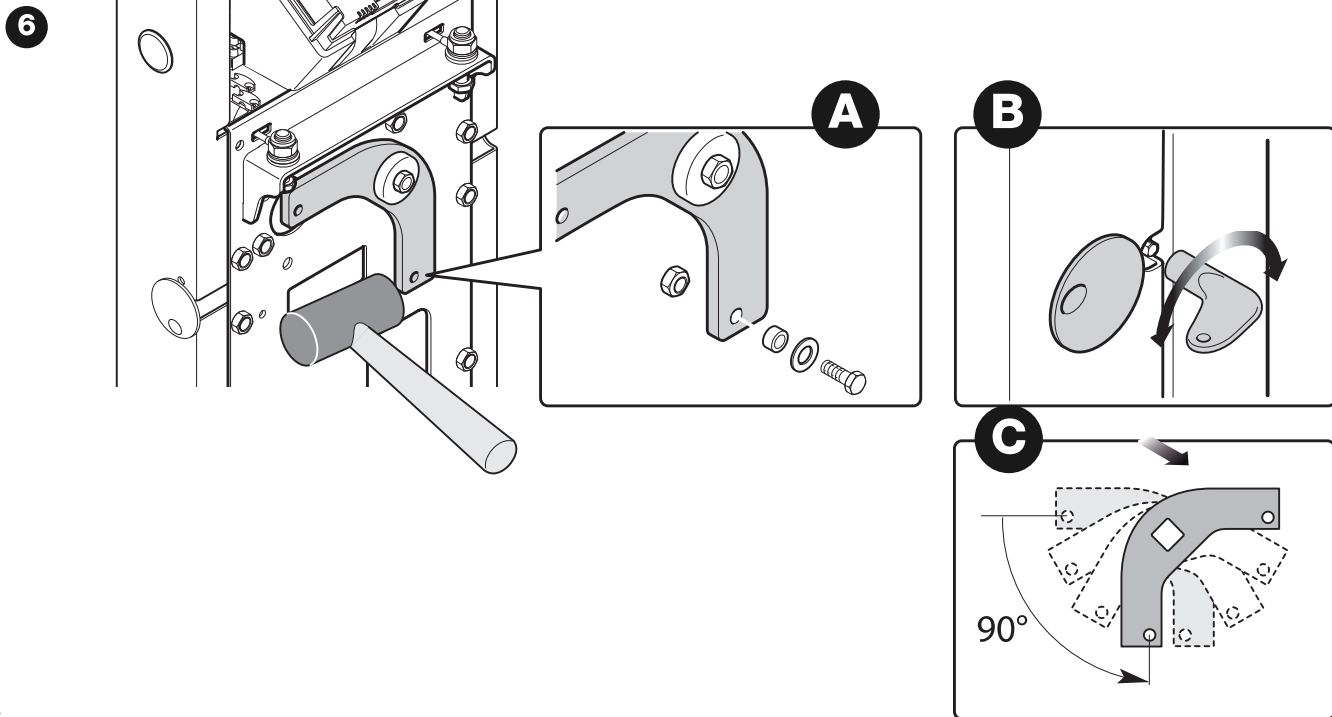

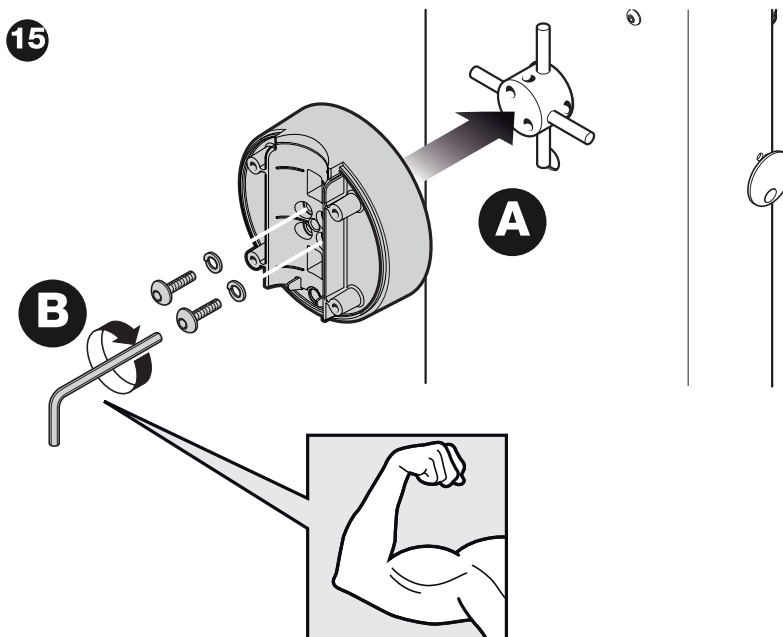
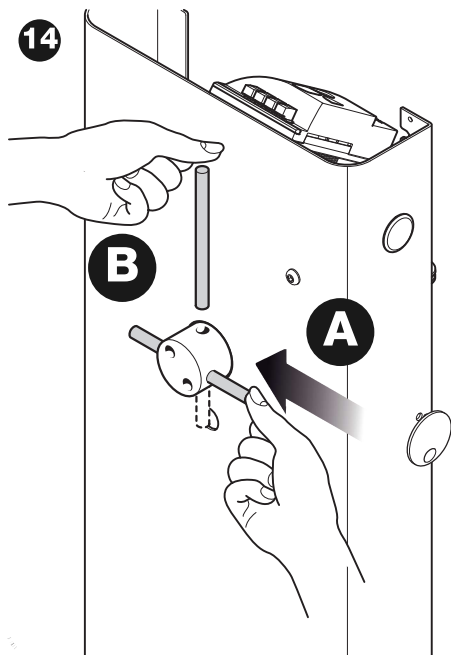
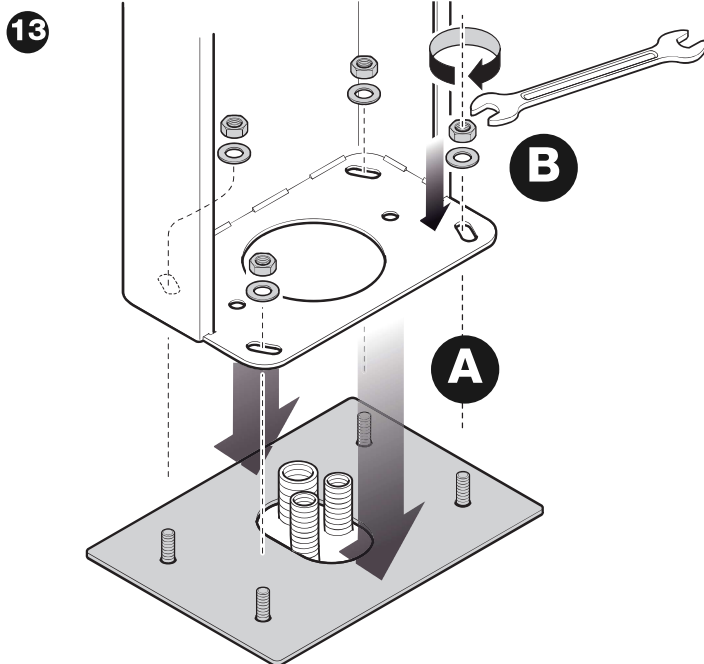
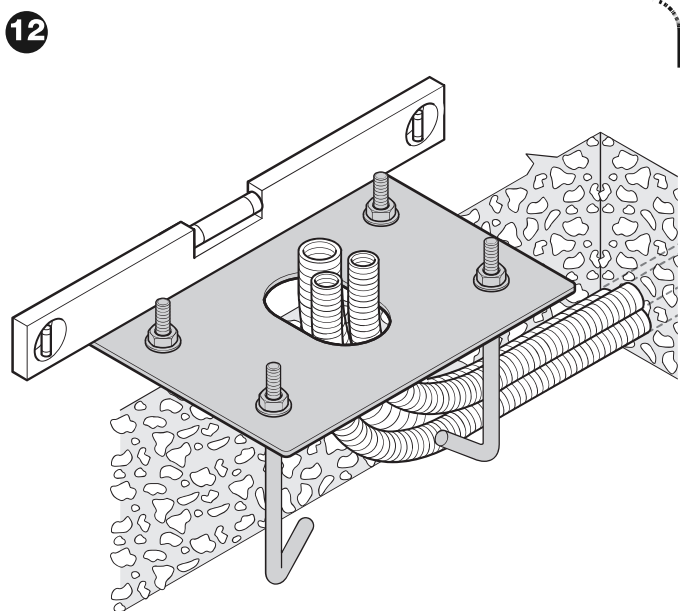
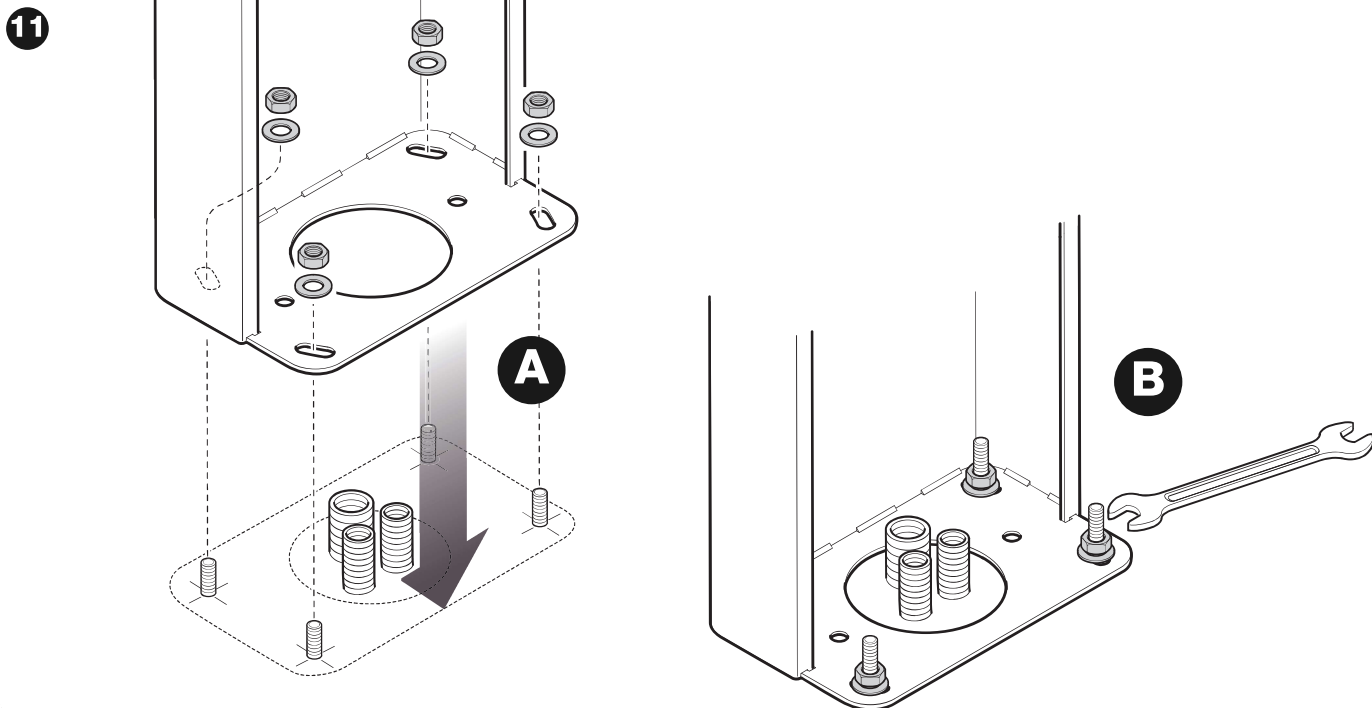

16

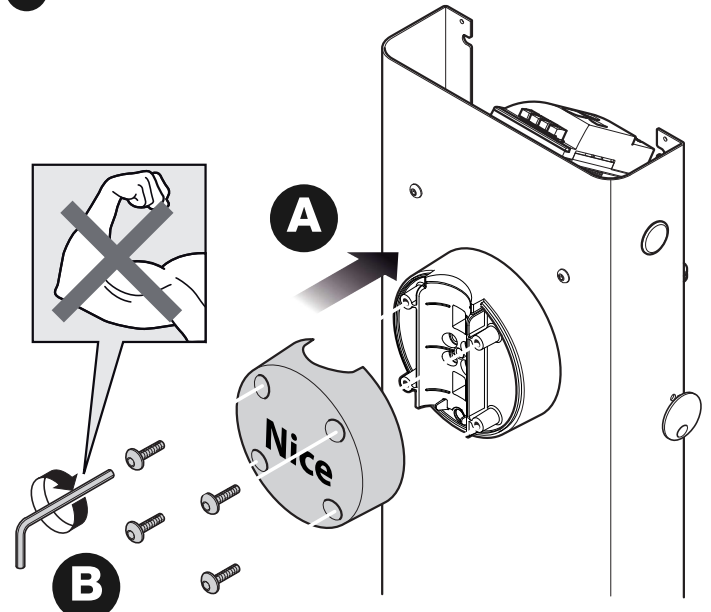

17

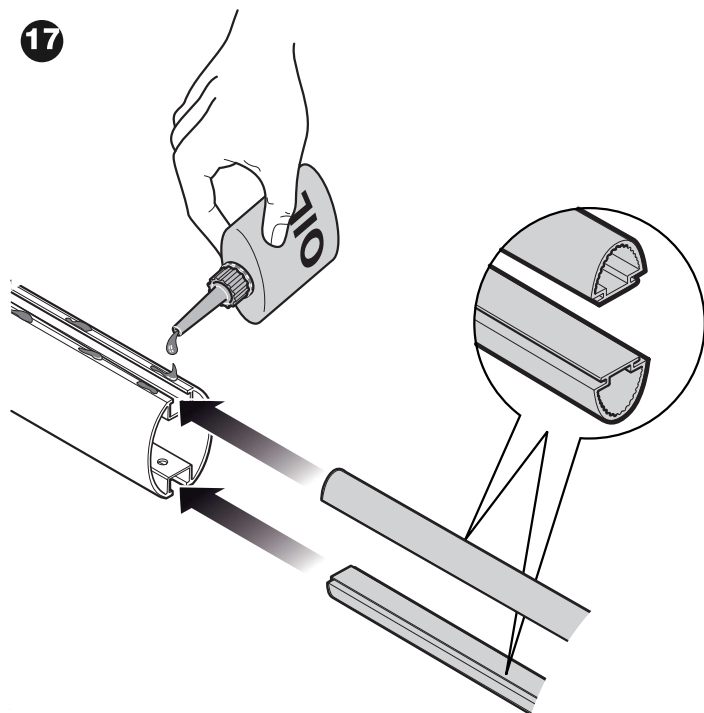

18

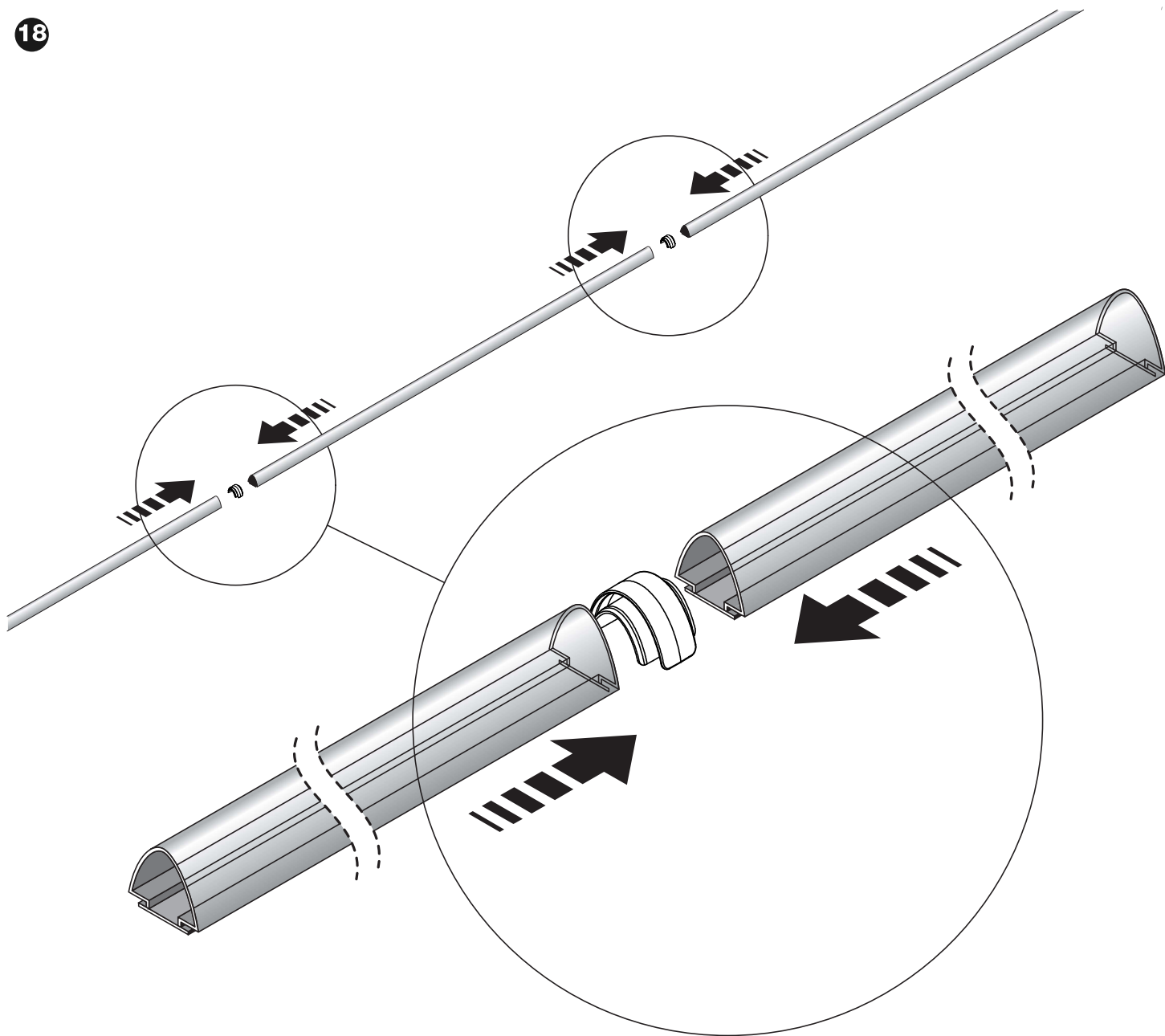

19

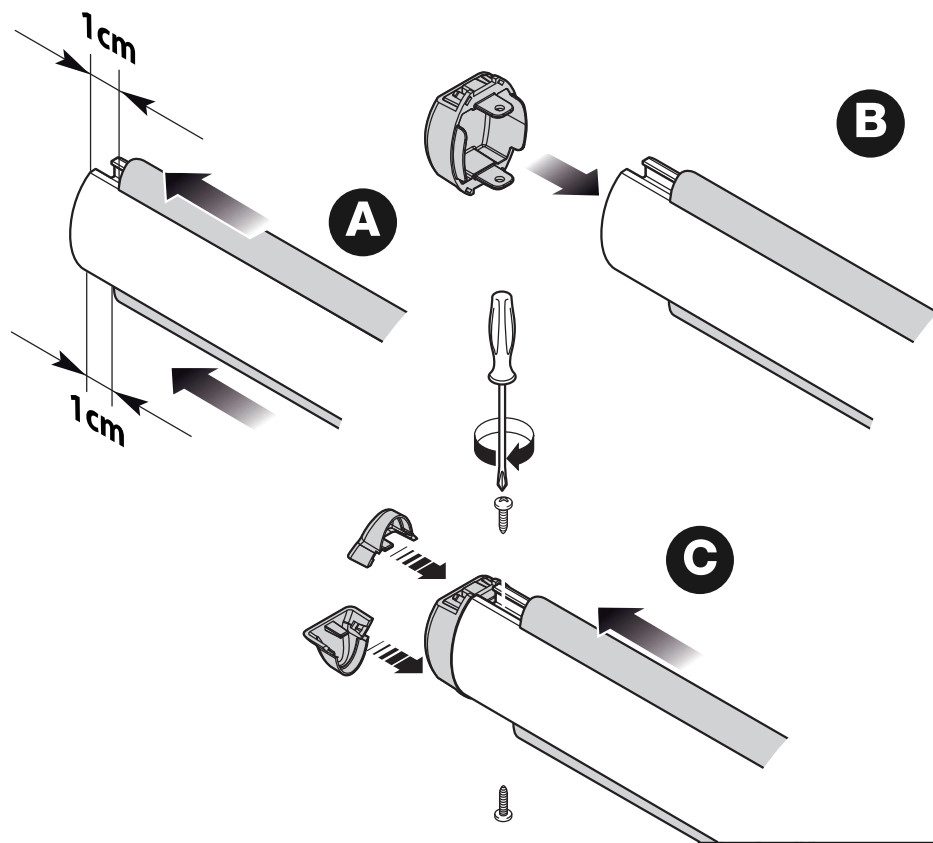

20

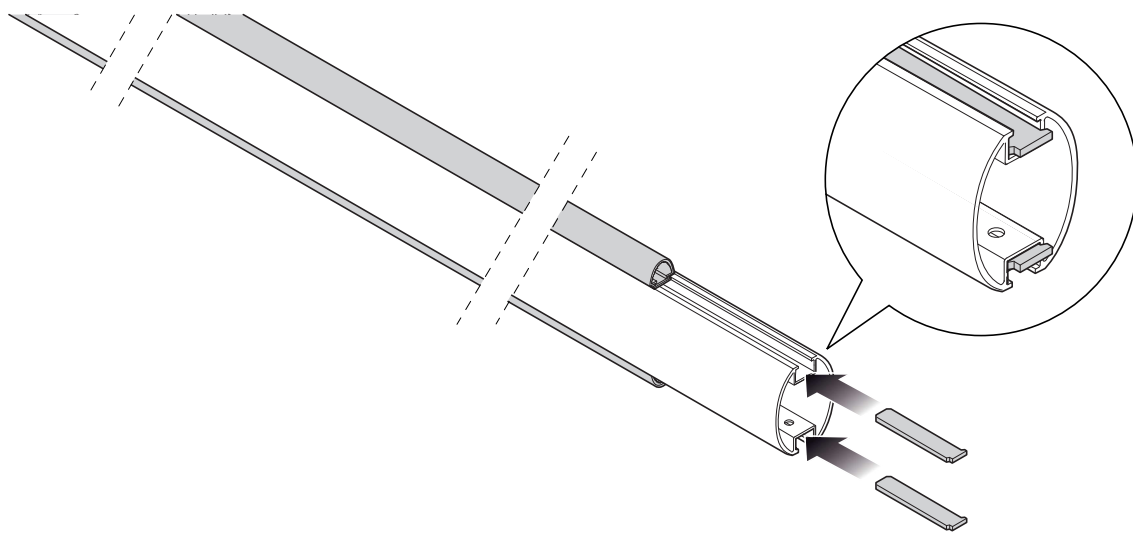

21

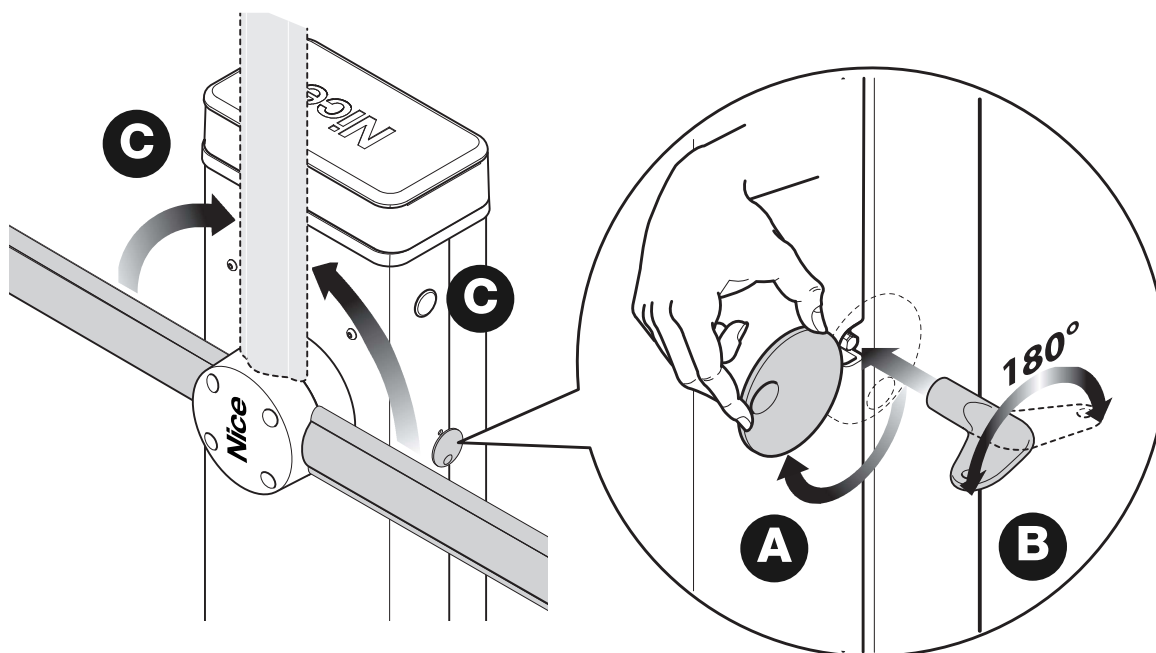

22

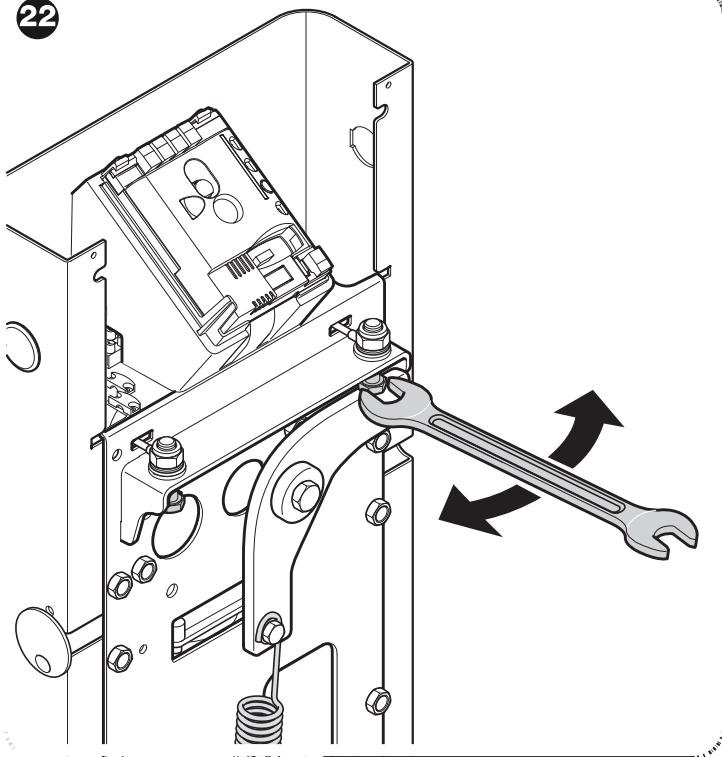

23

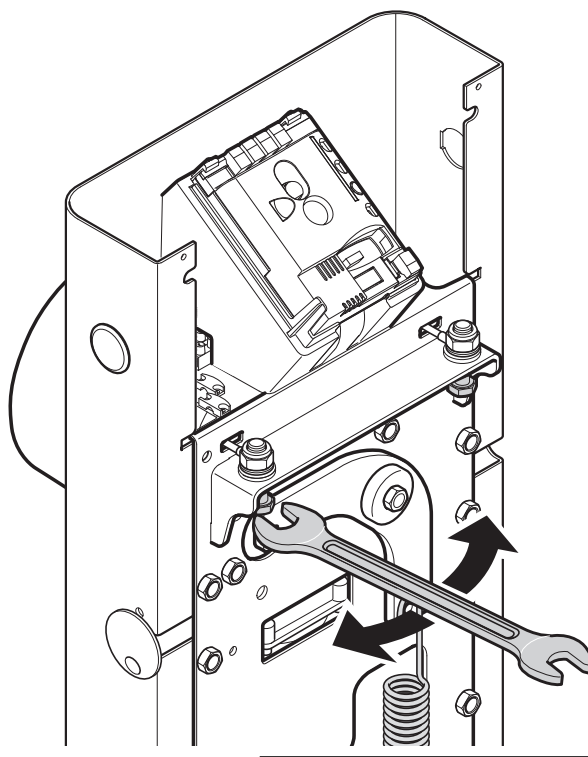

24

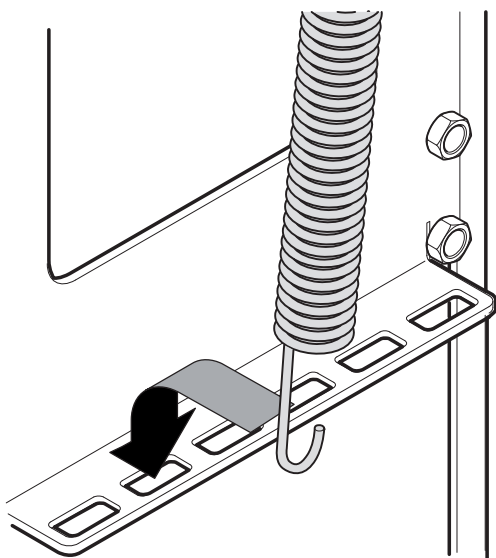

25

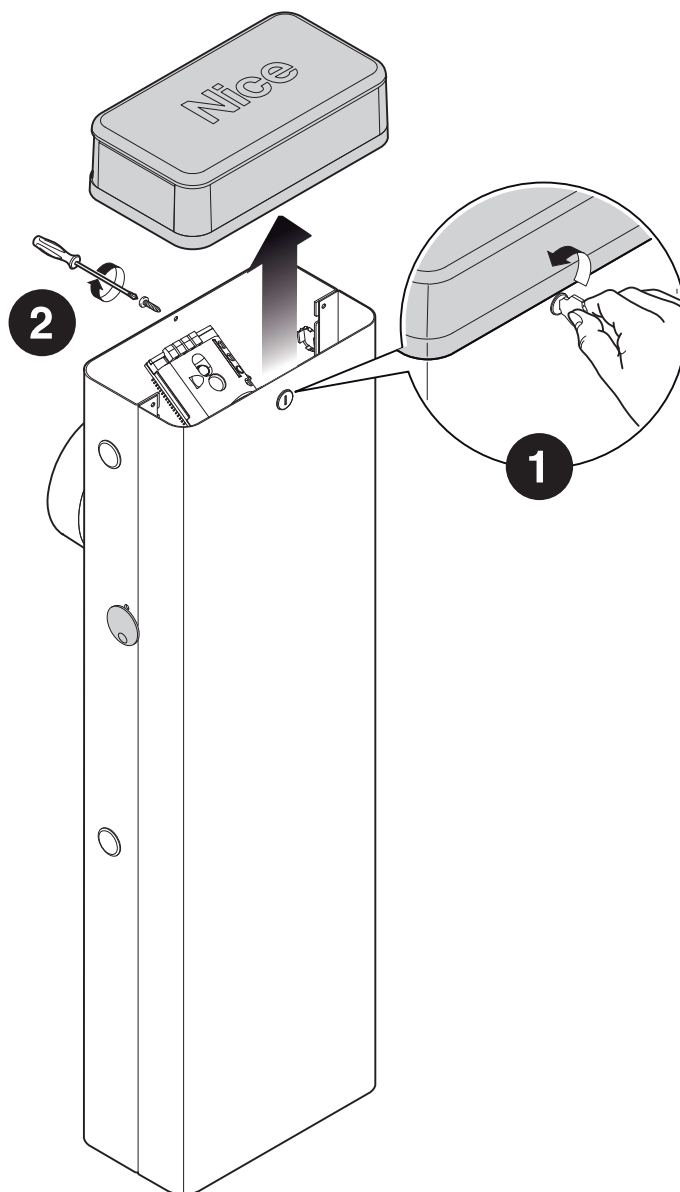

26

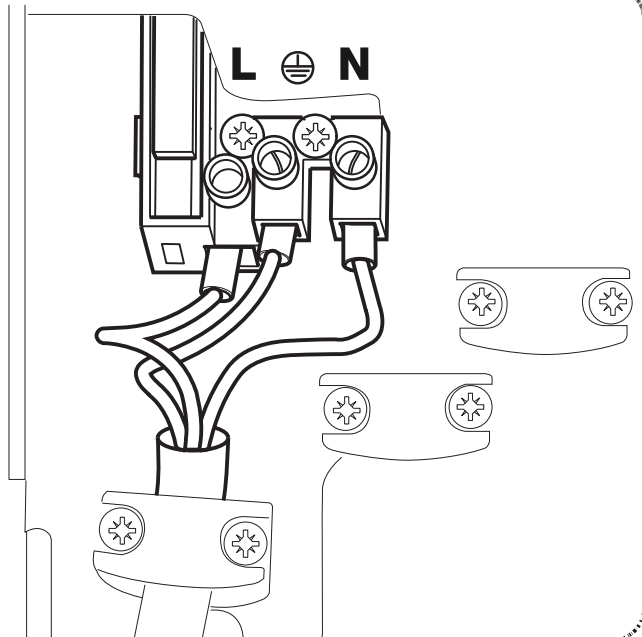

27

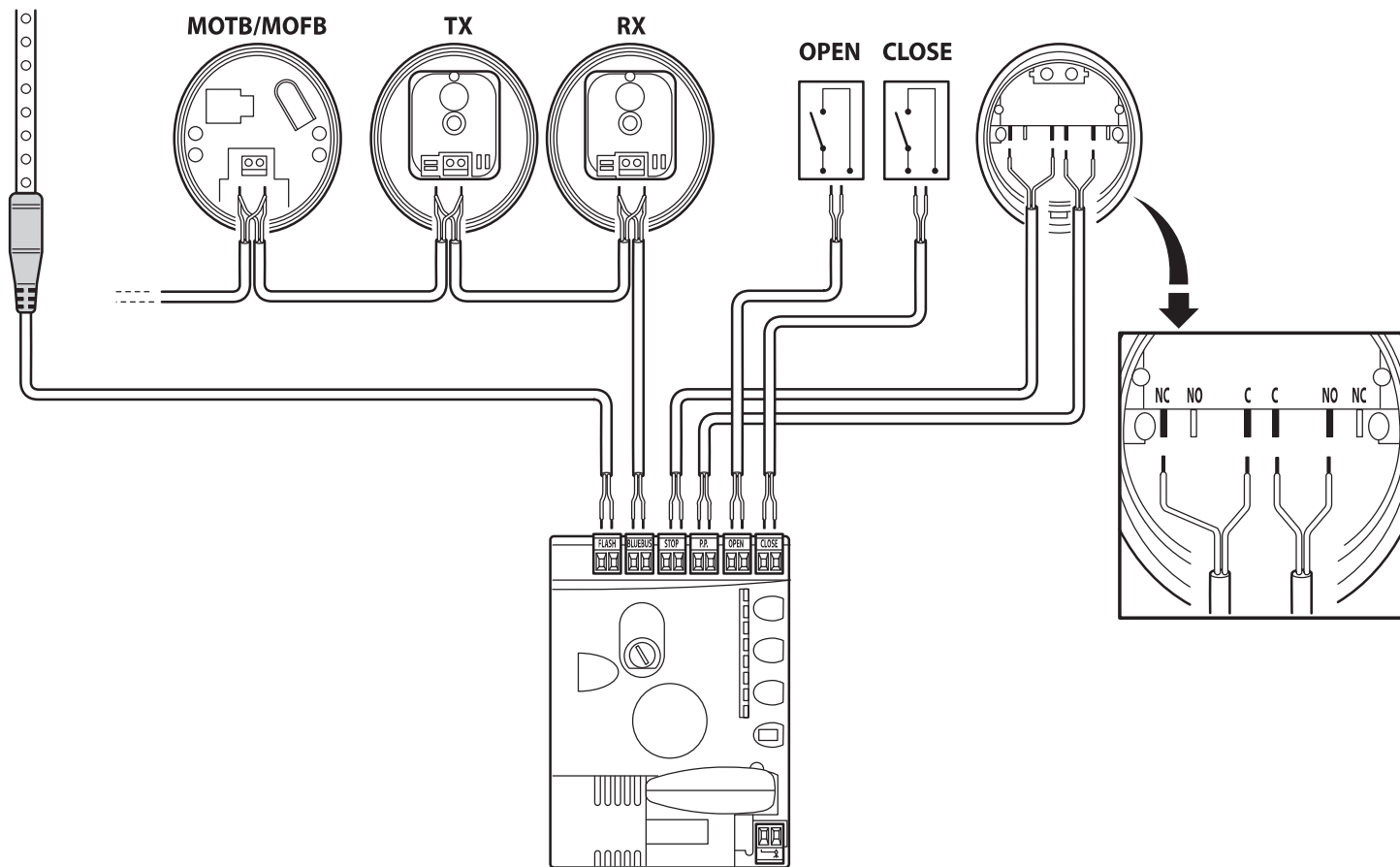

28

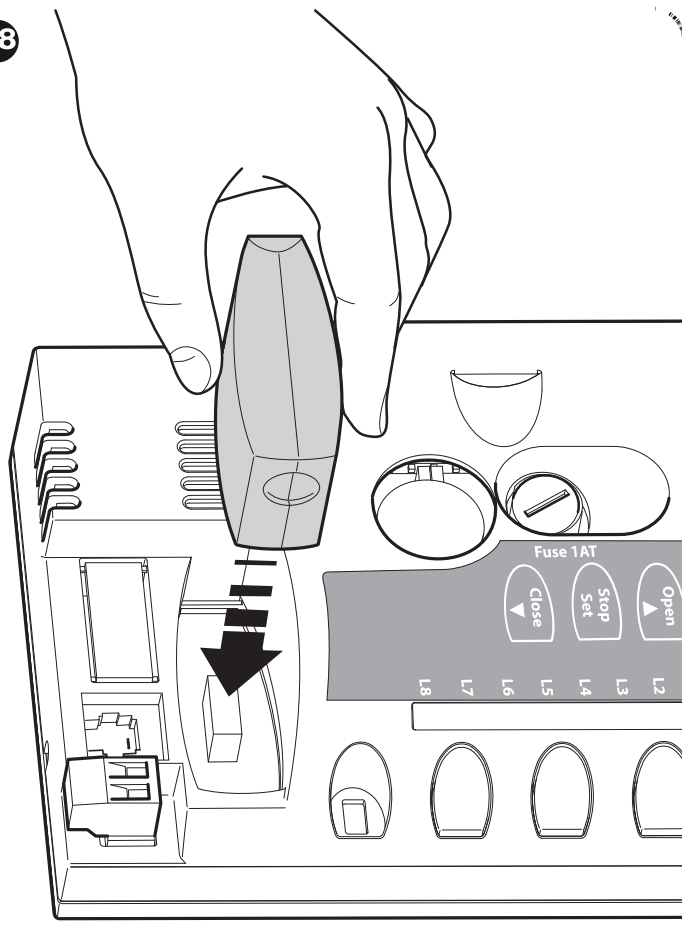

29

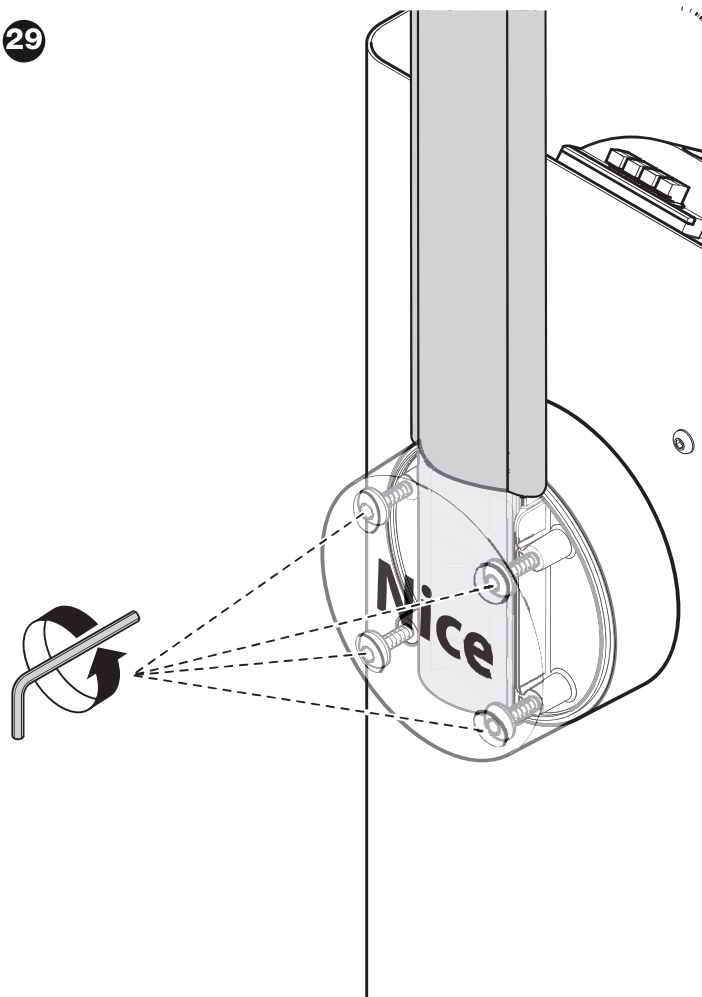



30

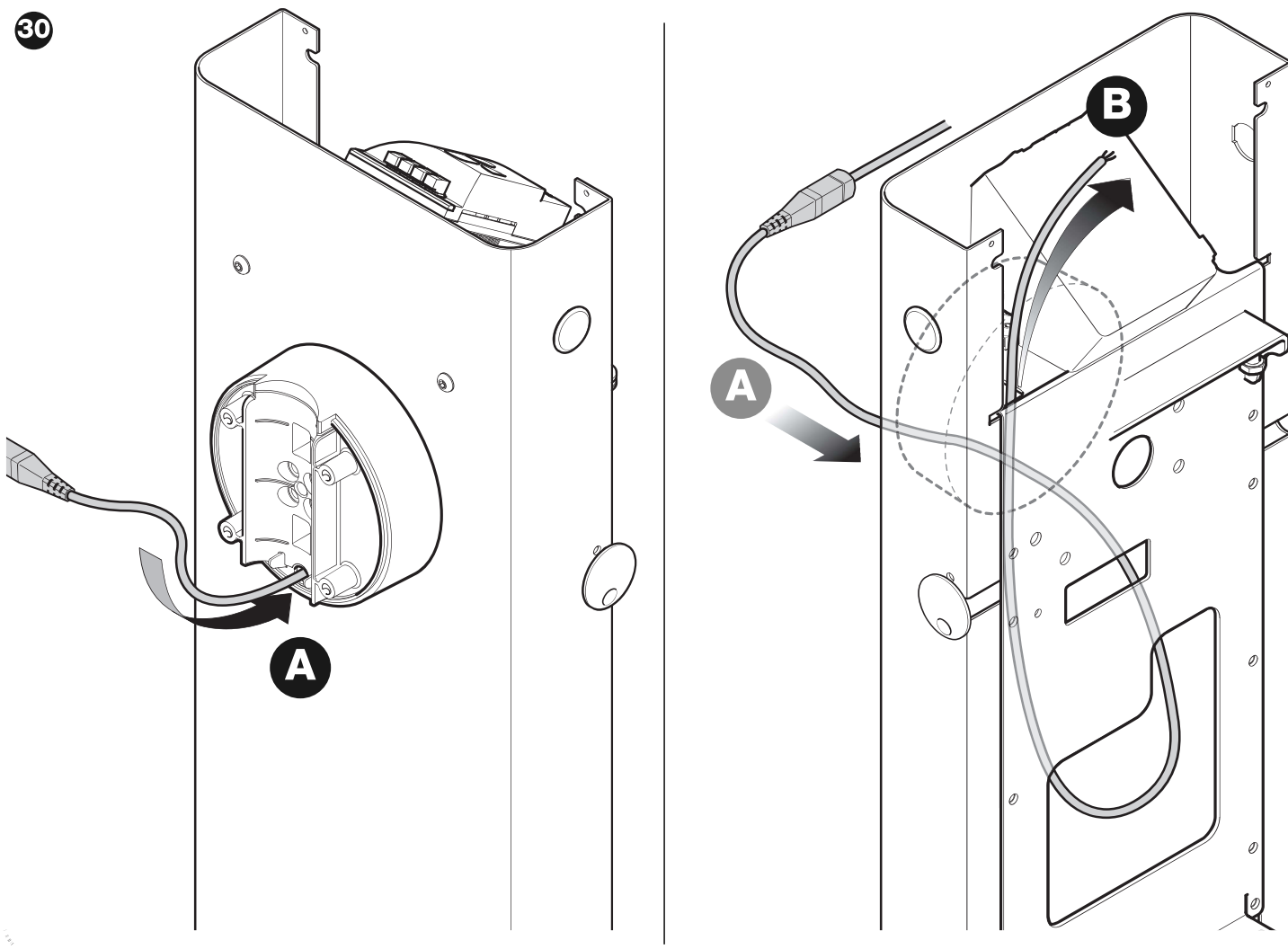

31

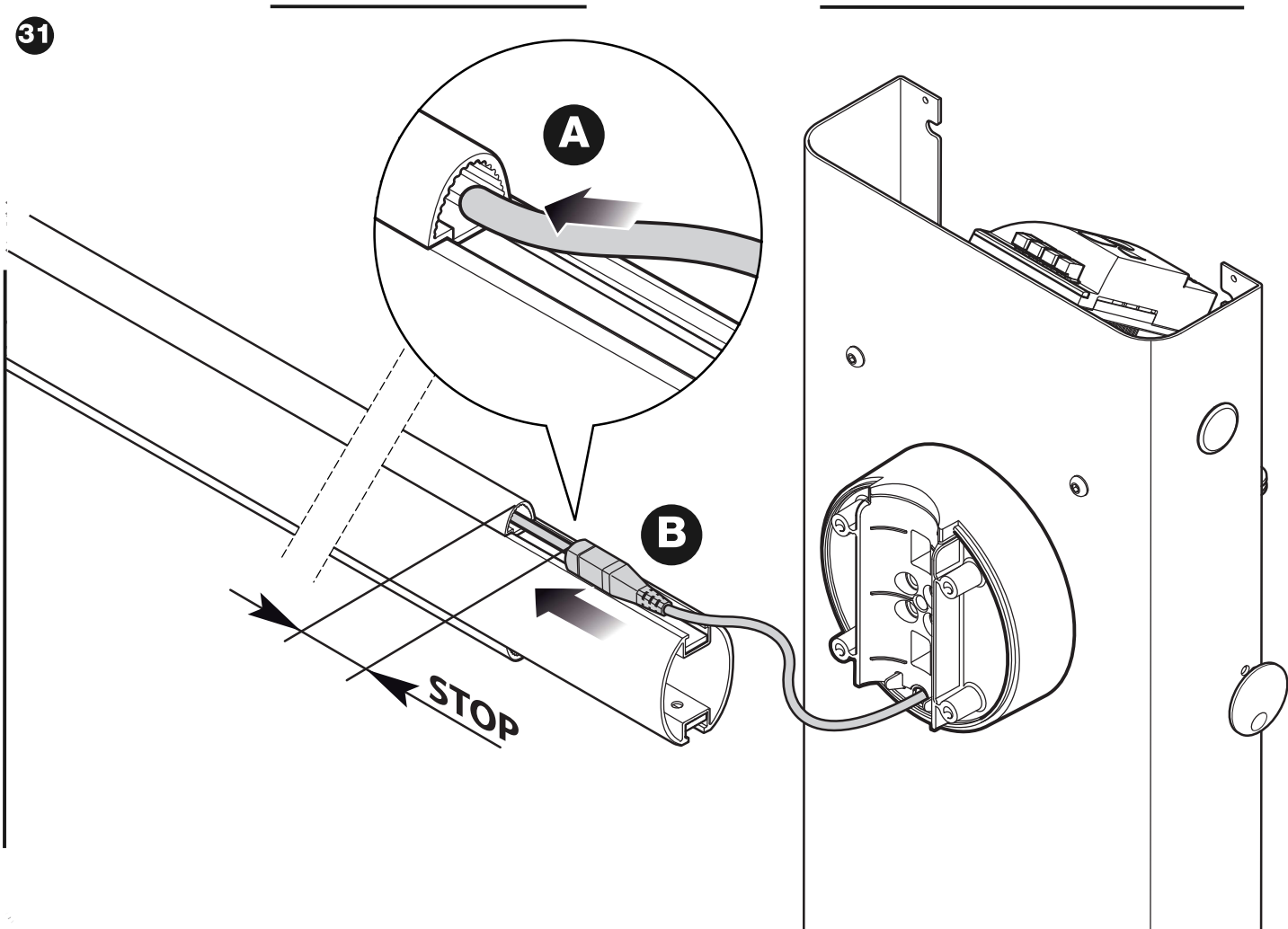

32

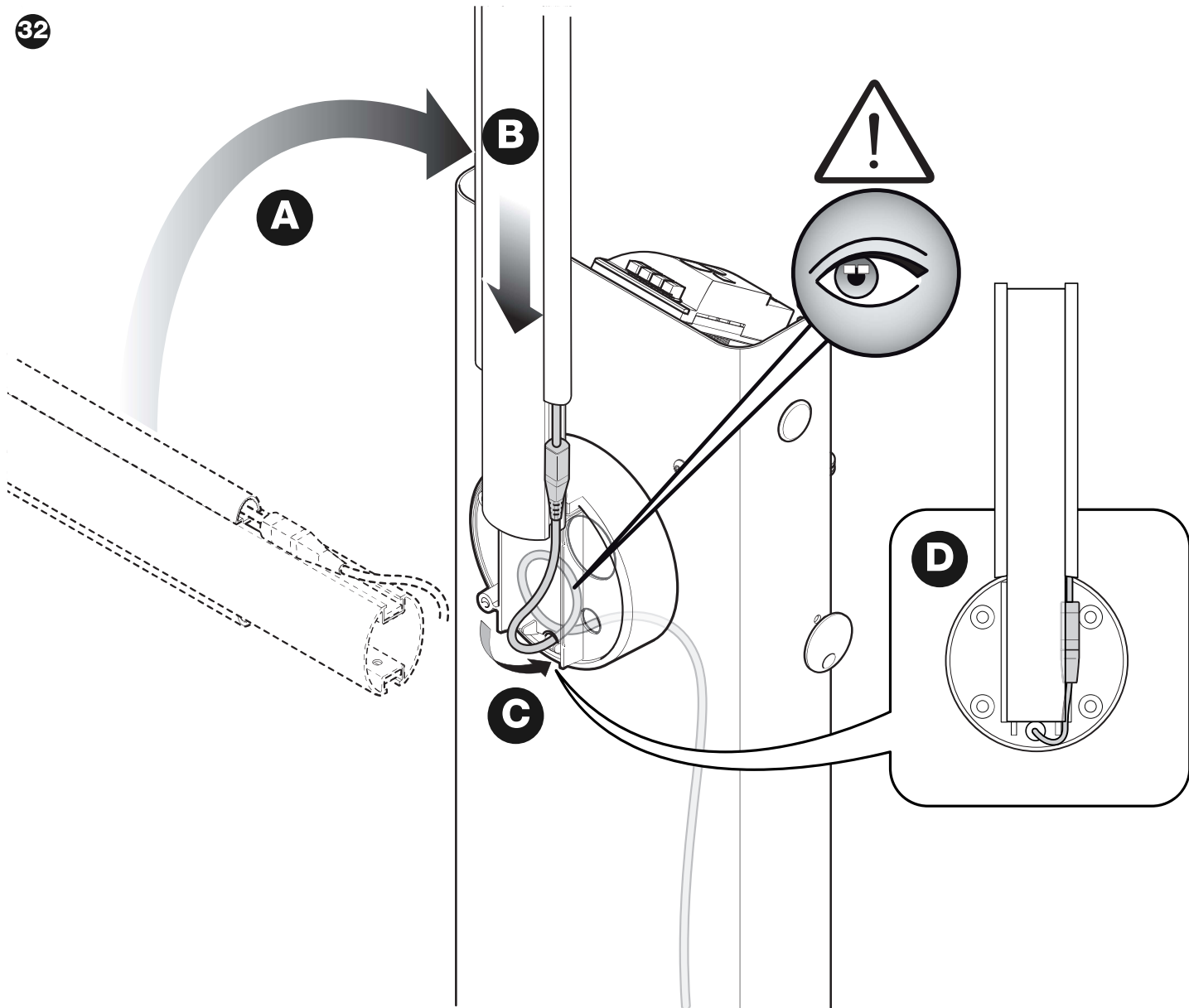

33

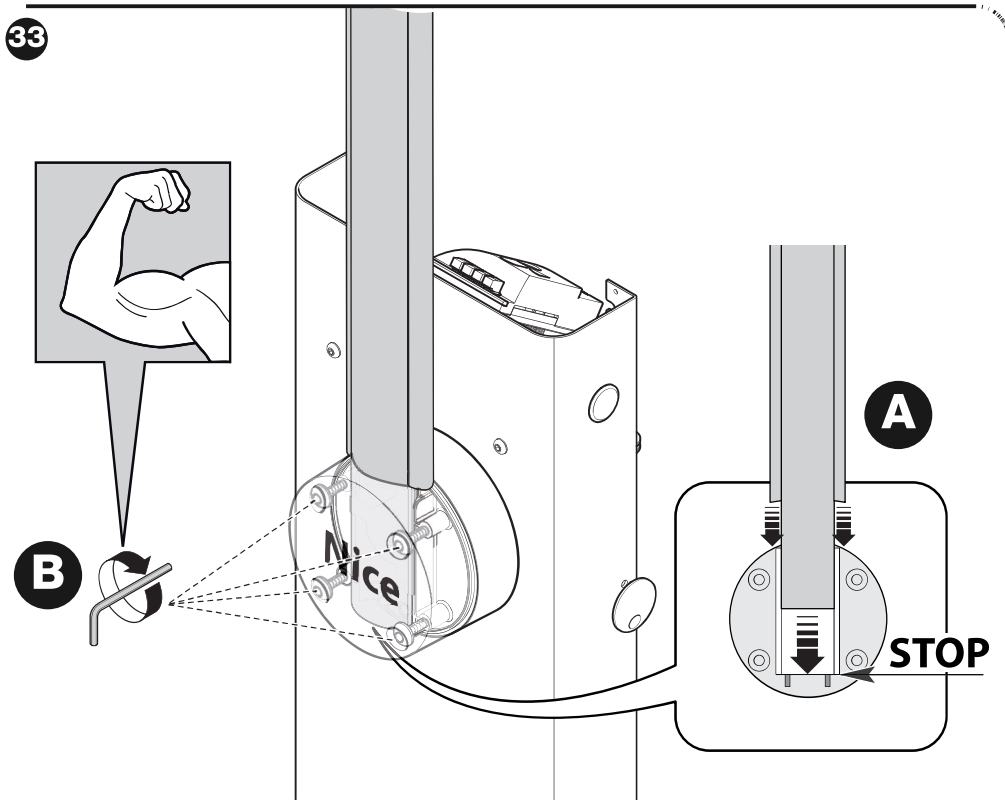

34

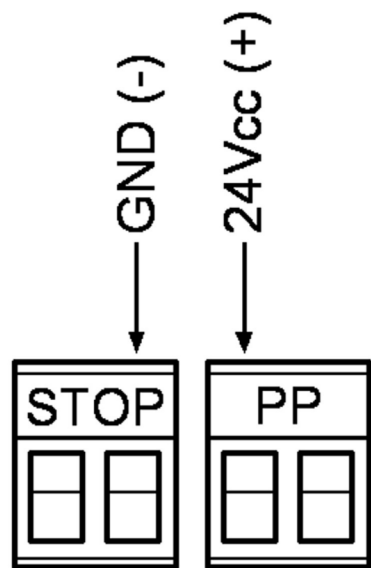

35

A

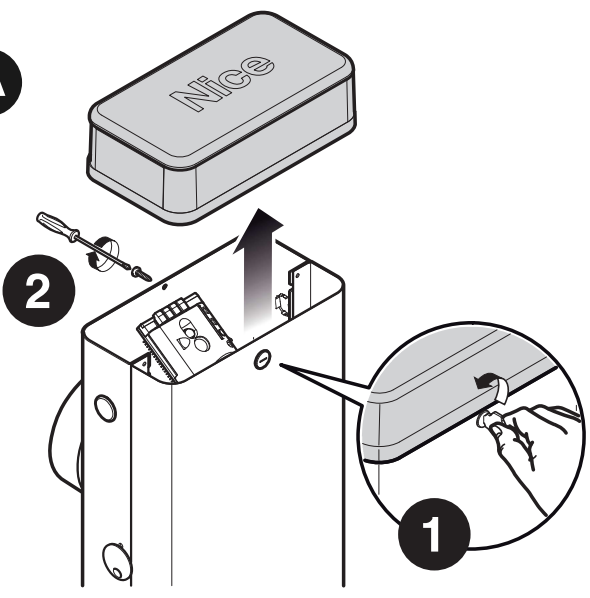

B

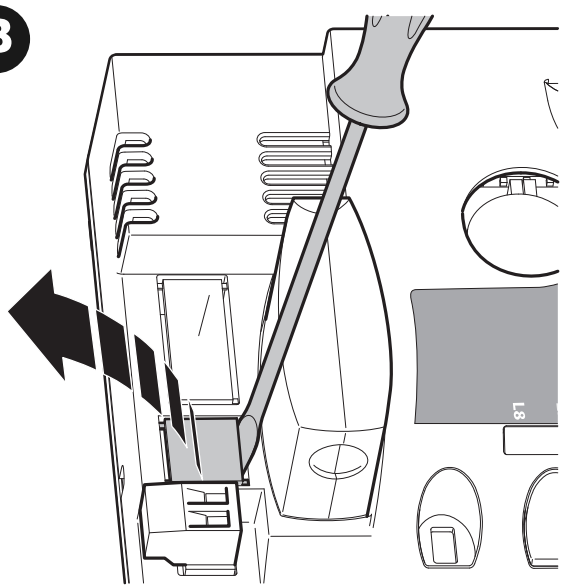

C

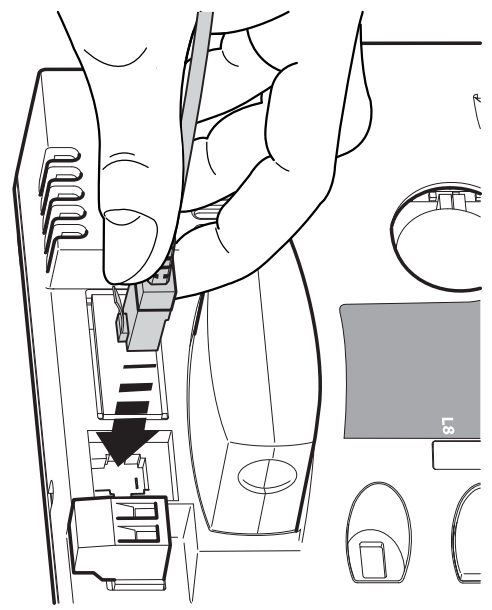

36

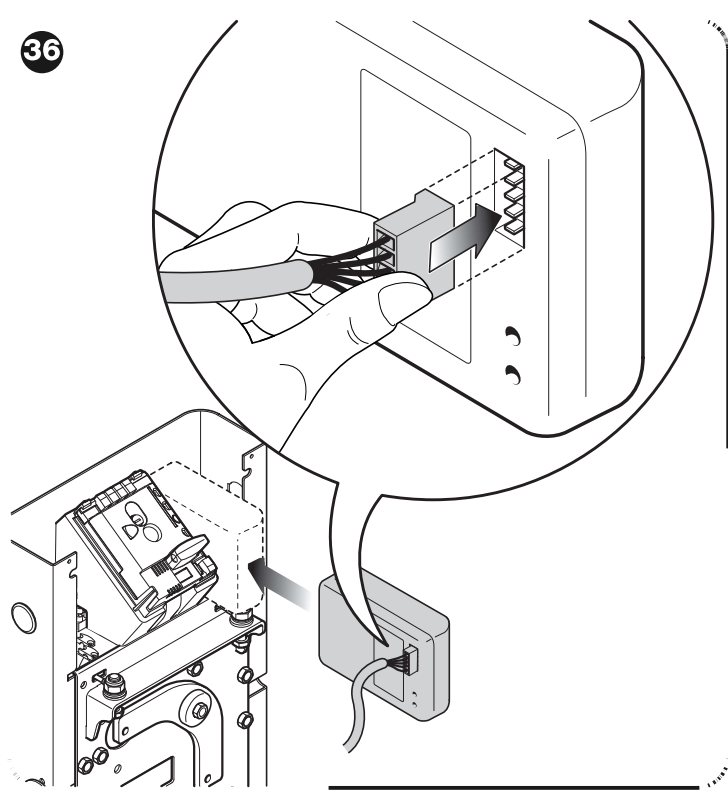

37

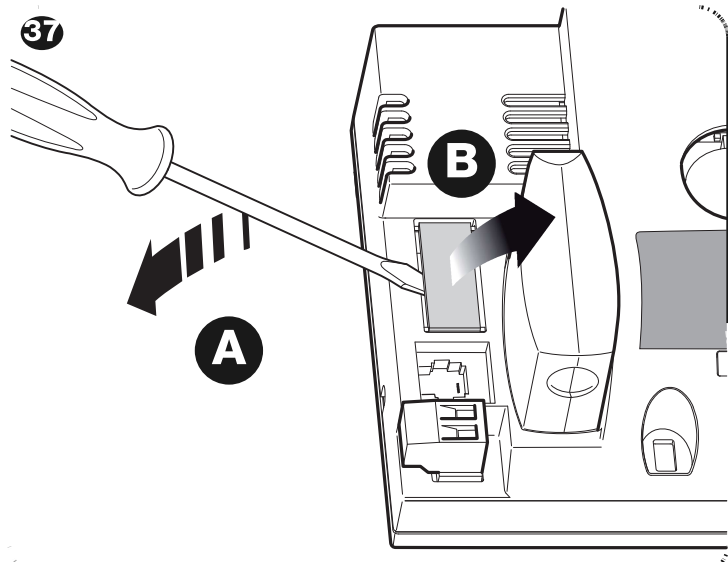

38

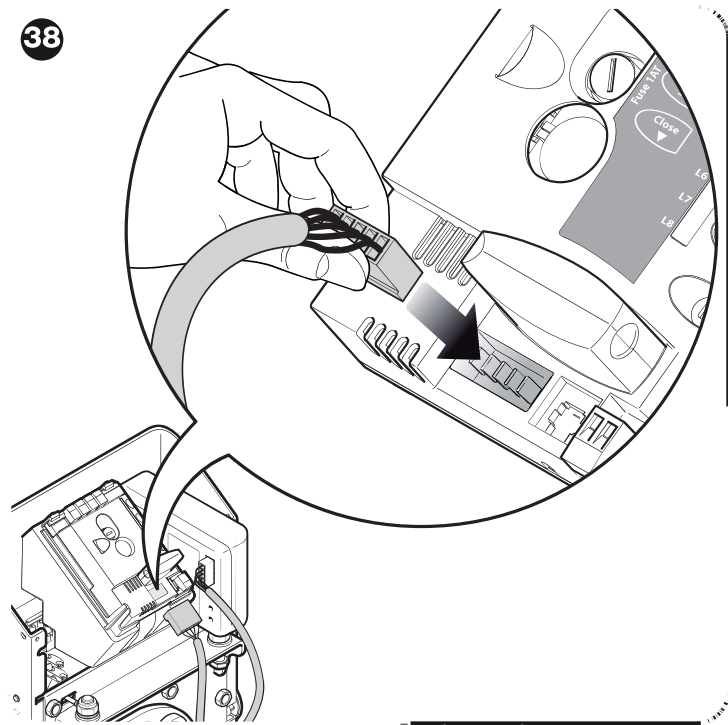

39

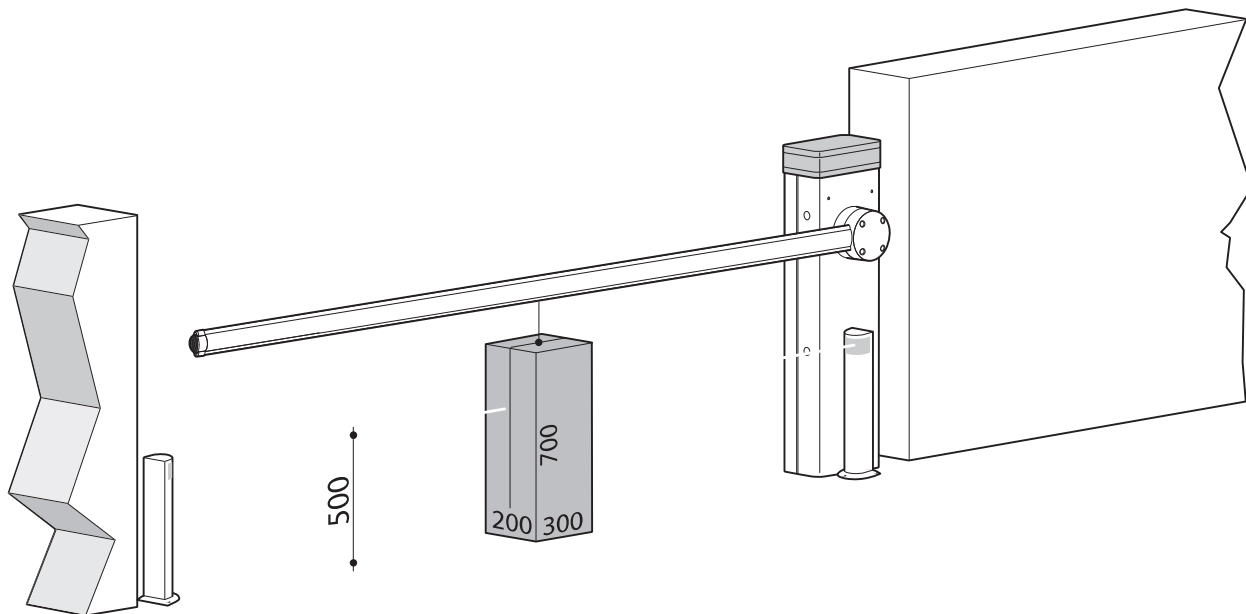

40

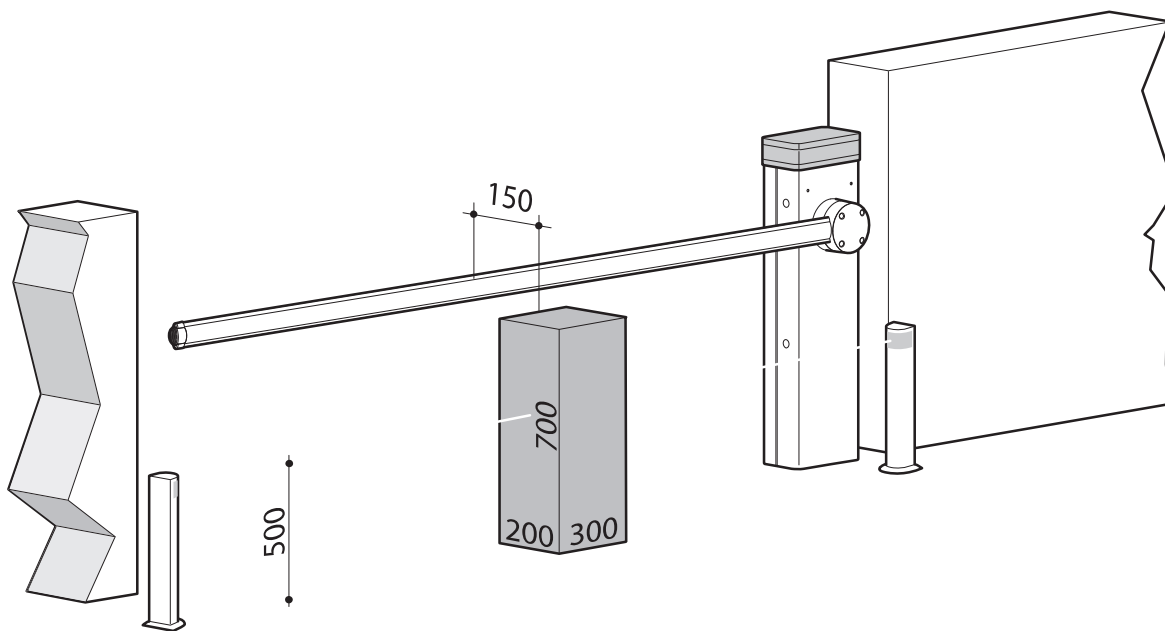

41

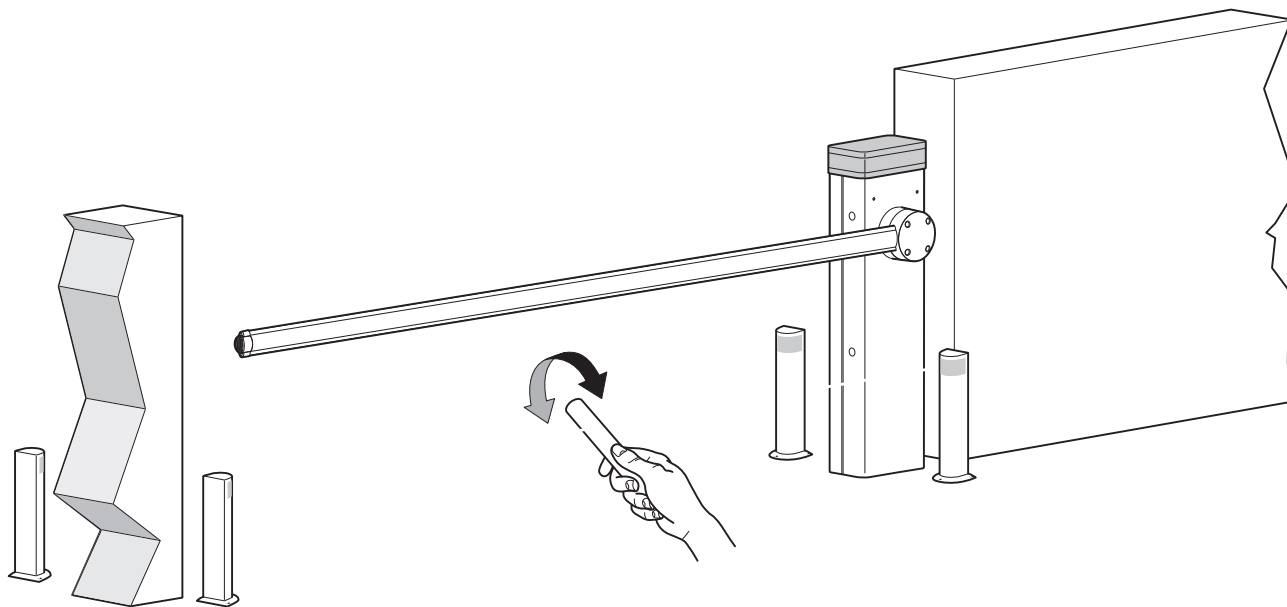

42

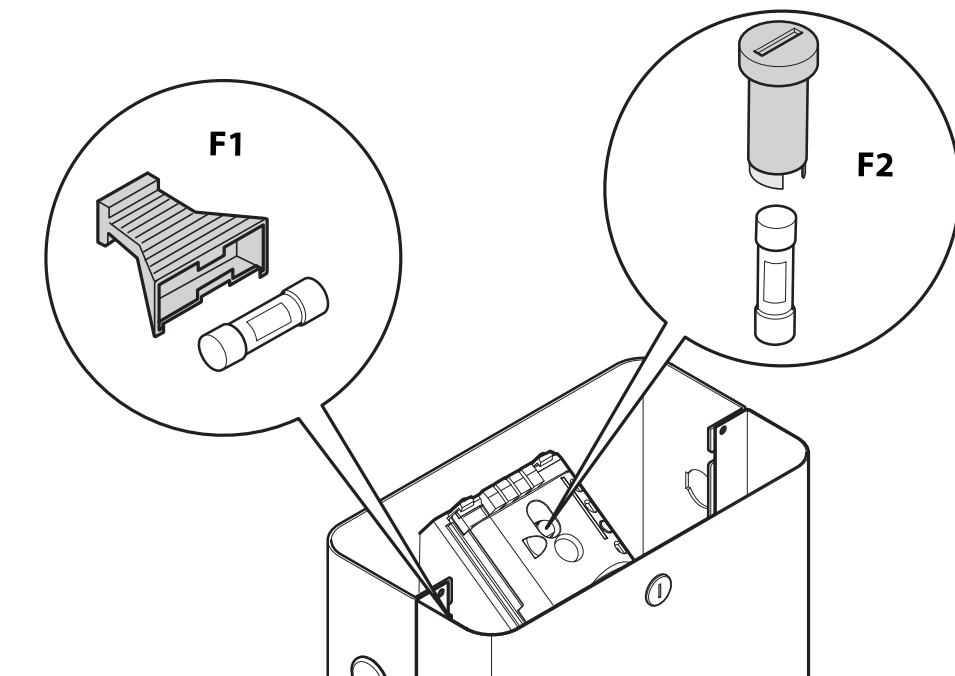

43

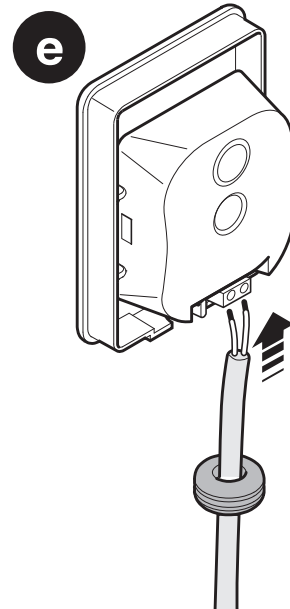
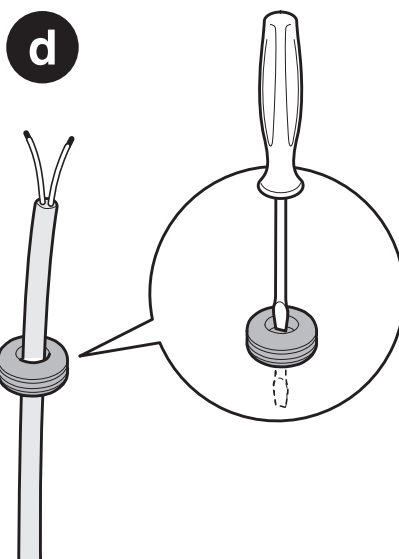
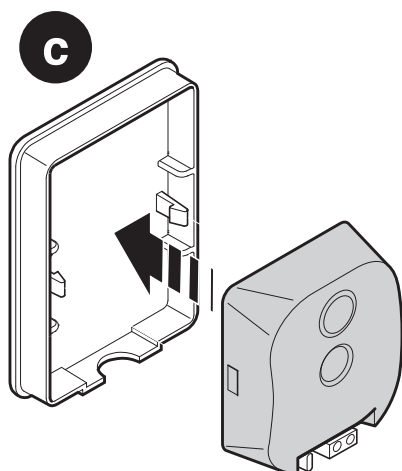
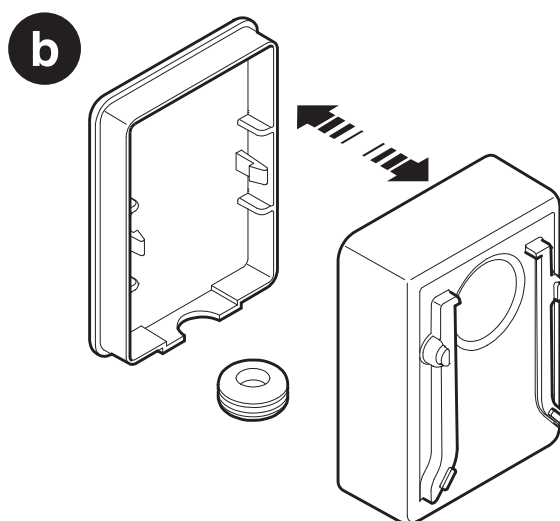
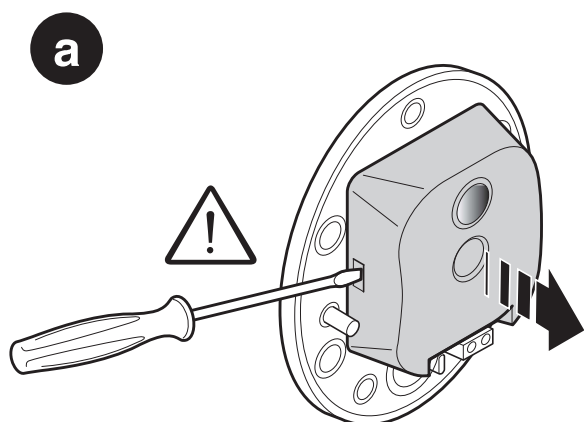



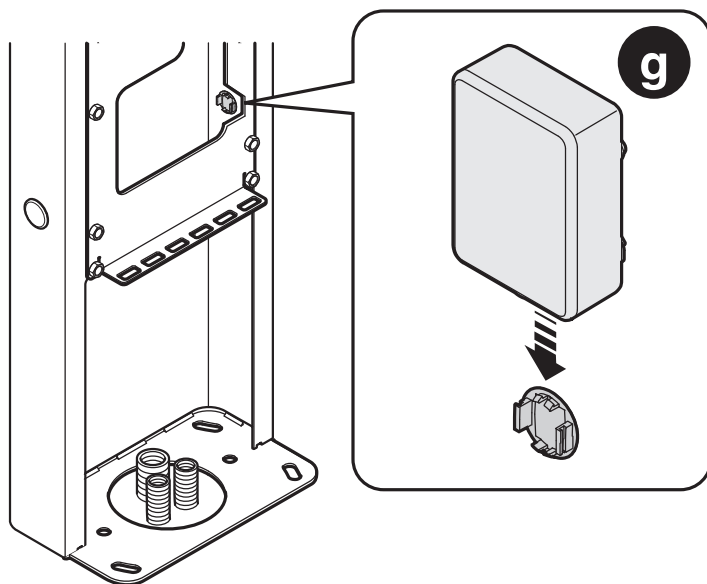
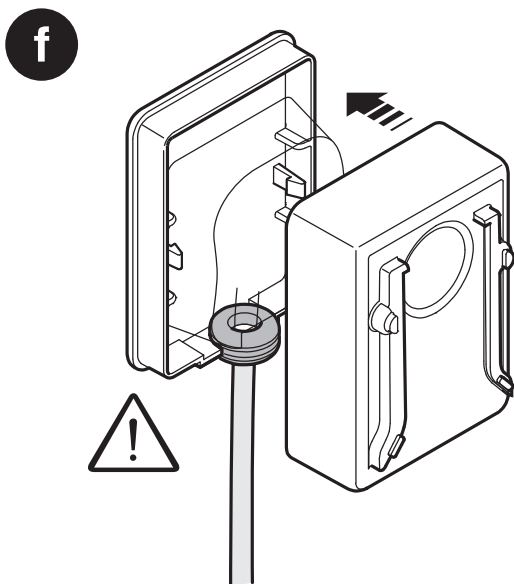

44

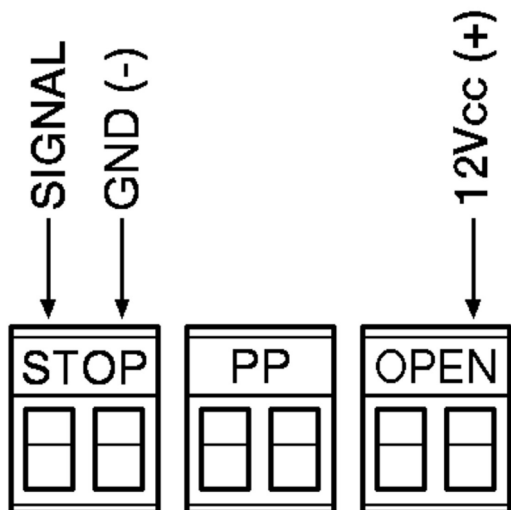

45

